

# HITACHI

Displays, Hitachi, Ltd.

Date; May 10, 2001

## TECHNICAL DATA

### TX36D70VC1CAF

#### CONTENTS

| No. | I t e m                               | Sheet No.      | Page      |
|-----|---------------------------------------|----------------|-----------|
| —   | COVER                                 | 3284TTD 1456-1 | 1-1/1     |
| —   | APPLICATIONS                          | 3284TTD 1456-1 | 2-1/1     |
| 1   | ABSOLUTE MAXIMUM RATING               | 3284TTD 1456-1 | 3-1/2~2/2 |
| 2   | OPTICAL CHARACTERISTICS               | 3284TTD 1456-1 | 4-1/2~2/2 |
| 3   | ELECTRICAL CHARACTERISTICS            | 3284TTD 1456-1 | 5-1/1     |
| 4   | BLOCK DIAGRAM                         | 3284TTD 1456-1 | 6-1/1     |
| 5   | INTERFACE PIN CONNECTION              | 3284TTD 1456-1 | 7-1/3~3/3 |
| 6   | INTERFACE TIMING FOR LVDS TRANSMITTER | 3284TTD 1456-1 | 8-1/3~3/3 |
| 7   | DIMENSIONAL OUTLINE                   | 3284TTD 1456-1 | 9-1/1     |

Note : This specifications is still tentative under development of the module and it includes targert.

Then it may be revised without notice by review on the characteristics, etc.  
Please check the latest specifications in using the module.

|               |            |                |      |       |
|---------------|------------|----------------|------|-------|
| Hitachi, Ltd. | Sh.<br>No. | 3284TTD 1456-1 | Page | 1-1/1 |
|---------------|------------|----------------|------|-------|

## APPLICATIONS

This specification is applied to the following TFT Liquid Crystal Display Module with Back-light unit and LVDS (Low Voltage Differential Signaling) Interface.

Note : Inverter device for Back-light is not built in so it should be prepared by yourself.

- Type name : **TX36D70VC1CAF**
- Display Area : H285.7×V214.3 [mm]
- Display Pixels : H1024×V768 [pixels]  
(Display Dots) (H(1024×3)×V768 dots)
- Pixel Pitch : H 0.279×V 0.279 [mm]
- Color Pixel Arrangement : R·G·B Vertical Stripe
- Display Mode : Transmissive Mode  
Normally White Mode
- Color Number : 262k Colors
- Interface : LVDS
- Front side Polarizer : Polarizer with Antiglare Coating
- Back-Light : A Cold Cathode Fluorescent Lamp  
(Inverter is not included)
- Dimensions Outlines : H298.5×V226.95×t6.0MAX [mm]
- Weight : 435 (typ.) [g]
- Power Supply : 3.3V

# 1. ABSOLUTE MAXIMUM RATINGS

## 1.1 ENVIRONMENTAL ABSOLUTE MAXIMUM RATINGS

| ITEM                       | OPERATING      |            | STORAGE        |           | UNIT             | NOTE |
|----------------------------|----------------|------------|----------------|-----------|------------------|------|
|                            | MIN.           | MAX.       | MIN.           | MAX.      |                  |      |
| Ambient Temperature        | 10             | 40         | -20            | 60        | °C               | 1)   |
| Humidity                   | 2)             |            | 2)             |           | %RH              | 1)   |
| Vibration                  | -              | 4.9 (0.5G) | -              | 19.6 (2G) | m/s <sup>2</sup> | 3)   |
| Shock                      | -              | 29.4 (3G)  | -              | 490 (50G) |                  | 4)   |
| Corrosive Gas              | NOT ACCEPTABLE |            | NOT ACCEPTABLE |           | -                |      |
| Illuminance of LCD surface | -              | 50,000     | -              | 50,000    | lx               |      |

Note 1) Environmental temperature and humidity of this unit, not of system installed with this unit.  
At low temperature the brightness of CFL drop and the life time of CFL become to be short.

2) Ambient temp  $T_a \leq 40^\circ\text{C}$  : 85%RH MAX. without condensation.  
 $T_a > 40^\circ\text{C}$  : Absolute humidity must be lower than the humidity of 85%RH at  $40^\circ\text{C}$ .

3) 20~50Hz, (Except resonance frequency)

4) 7ms

## 1.2 ELECTRICAL ABSOLUTE MAXIMUM RATINGS

### (1) TFT LIQUID CRYSTAL DISPLAY MODULE

V<sub>SS</sub>=0V

| ITEM                     | SYMBOL | MIN. | MAX. | UNIT | NOTE   |
|--------------------------|--------|------|------|------|--------|
| Power Supply Voltage     | VDD    | 0    | 4.0  | V    |        |
| Electrostatic Durability | VESD0  | ±100 |      | V    | 1), 2) |
|                          | VESD1  | ± 8  |      | kV   | 1), 3) |

Note 1) 200pF-250Ω, 25°C-70%RH.

2) I/F Connector pins are subjected.

3) The Surface of Metal bezel and LCD are subjected.

### (2) BACK-LIGHT UNIT

GND=0V

| ITEM         | SYMBOL | MIN. | MAX. | UNIT              |
|--------------|--------|------|------|-------------------|
| Lamp Current | IL     | 0    | 7    | mA <sub>rms</sub> |
| Lamp Voltage | VL     | 0    | 2000 | V <sub>rms</sub>  |

### 1.3 Connection between PC Ground and Metal frame.

Metal frame of the module should be grounded with PC's ground in case that protection film is being peeled off while operating the module. Unless you connect between metal frame and PC's Ground. PC's system happens to shut down due to the influence of electrostatic discharge caused by peeling off the protection film.

## 2. OPTICAL CHARACTERISTICS

The following items are measured when the conditions of this unit (TFT panel and Back-light) and measuring systems are stable.

The ambient light excluding Back-light is nothing.

- Measuring equipment : TOPCON BM-7, Pritchard 1980A, or equivalent.
- Measuring point : Active area center

Temperature of LCD=25°C, VDD=3.3V, fv=60Hz, IL=6mA  
Back-Light operation Frequency = (55)kHz

| ITEM               | SYMBOL | CONDITION                     | MIN. | TYP. | MAX. | UNIT              | NOTE |  |
|--------------------|--------|-------------------------------|------|------|------|-------------------|------|--|
| Contrast Ratio     | CR     | $\theta = 0^\circ$<br>Note 1) | 100  | 150  | —    | —                 | 2)   |  |
| Brightness (White) | Bwh    |                               | 120  | 150  | —    | cd/m <sup>2</sup> |      |  |
| Color of CIE       | Red    |                               | x    | 0.53 | 0.58 | 0.63              | —    |  |
|                    |        |                               | y    | 0.28 | 0.33 | 0.38              |      |  |
|                    | Green  |                               | x    | 0.25 | 0.30 | 0.35              |      |  |
|                    |        |                               | y    | 0.51 | 0.56 | 0.61              |      |  |
|                    | Blue   |                               | x    | 0.09 | 0.14 | 0.19              |      |  |
|                    |        |                               | y    | 0.08 | 0.13 | 0.18              |      |  |
|                    | White  |                               | x    | 0.28 | 0.33 | 0.38              |      |  |
|                    |        |                               | y    | 0.29 | 0.34 | 0.39              |      |  |

Note 1) Definition of Viewing Angle

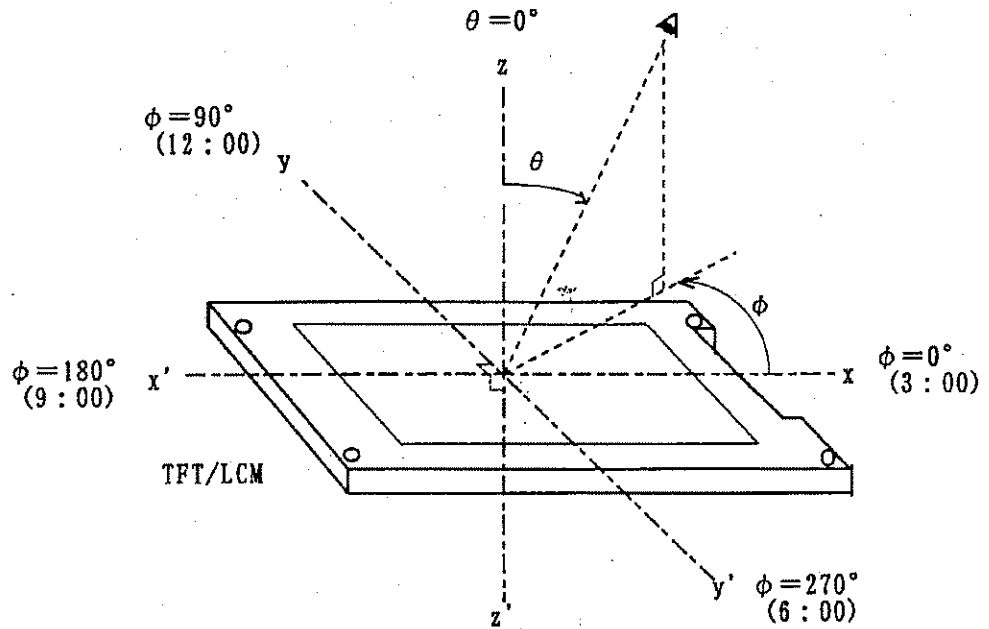

Note 2) Definition of Contrast Ratio (CR)

$$CR = \frac{\text{Brightness when displaying White raster}}{\text{Brightness when displaying Black raster}}$$

### 3. ELECTRICAL CHARACTERISTICS

#### (1) TFT LIQUID CRYSTAL DISPLAY MODULE

Ta=25°C, Vss=0V

| ITEM   | SYMBOL           | MIN.            | TYP. | MAX. | UNIT | NOTE     |
|--|------------------|-----------------|------|------|------|----------|
| Power Supply Voltage                                   | V <sub>DD</sub>  | 3.0             | 3.3  | 3.6  | V    |          |
| Differential Input Voltage for LVDS Receiver Threshold | Hi               | V <sub>IH</sub> | —    | —    | +100 | mV<br>1) |
|  | Lo               | V <sub>IL</sub> | -100 | —    | —    |          |
| Power Supply Current                                   | I <sub>DD</sub>  | —               | 300  | 600  | mA   | 2), 3)   |
| Vsync Frequency  | f <sub>v</sub>   | —               | 60   | 65   | Hz   | 4)       |
| Hsync Frequency  | f <sub>H</sub>   | —               | 48.5 | 52.4 | kHz  | 4)       |
| DCLK Frequency   | f <sub>CLK</sub> | —               | 65   | 68   | MHz  | 4)       |

Note 1) VCM=+1.25V

VCM is common mode voltage of LVDS transmitter/receiver.

The input terminal of LVDS transmitter is terminated with 100Ω.

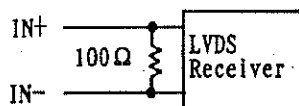

2) f<sub>v</sub>=60Hz, f<sub>CLK</sub>=65MHz, V<sub>DD</sub>=3.3V, DC Current.

Typ. value is measured when displaying Vertical-stripe (Black-Gray 7).

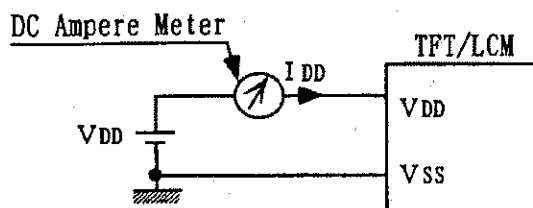

3) As this module contains 1.0A current fuse, prepare current source that is enough for cutting current fuse when a trouble happens.

4) For LVDS Transmitter Input

#### (2) BACK-LIGHT UNIT

Ta=25°C, GND=0V

| ITEM                  | SYMBOL         | MIN. | TYP. | MAX. | UNIT             | NOTE   |
|-----------------------|----------------|------|------|------|------------------|--------|
| Lamp Current          | I <sub>L</sub> | 3.5  | 5.0  | 6.0  | mArms            | 1), 2) |
| Lamp Voltage          | V <sub>L</sub> | —    | 650  | —    | V <sub>rms</sub> |        |
| Frequency             | f <sub>L</sub> | 50   | —    | 70   | kHz              | 3)     |
| Starting Lamp Voltage | V <sub>s</sub> | 1100 | —    |      | V <sub>rms</sub> | 4)     |
|                       |                | 1250 | —    |      |                  | 4), 5) |

Note 1) I<sub>L</sub> is Current of GND side.

2) Higher I<sub>L</sub> cause the short life time of CFL.

3) Lamp frequency may produce interference with Hsync frequency, causing beat or flicker on the display.

4) Starting Lamp Voltage is applied more than V<sub>s</sub>(min).

5) Ta=10°C

#### 4. BLOCK DIAGRAM

##### (1) TFT LIQUID CRYSTAL DISPLAY MODULE

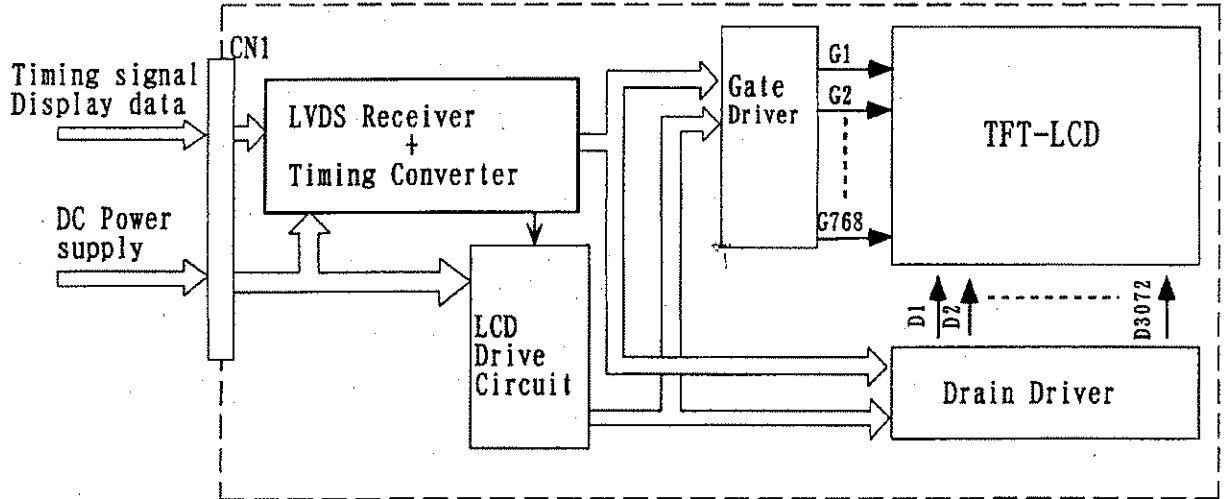

##### (2) BACK-LIGHT UNIT

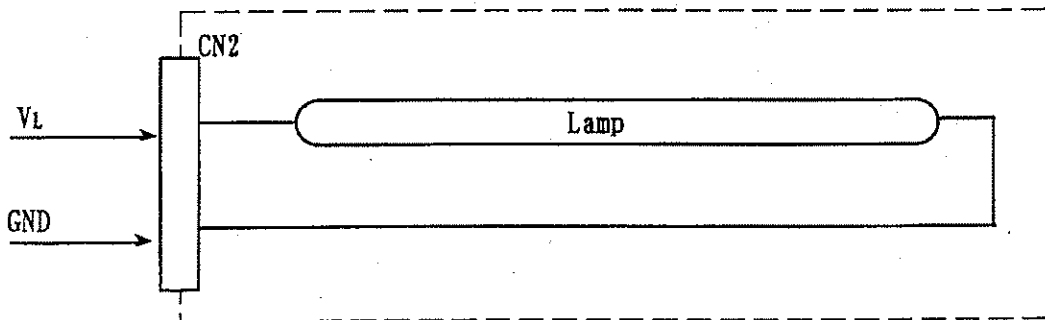



## 5. INTERFACE PIN CONNECTION

### (1) TFT LIQUID CRYSTAL DISPLAY MODULE

CN1 《JAE FI-SEB20P-HF13 or equivalent》

| Pin No | SYMBOL | FUNCTION                  | NOTE |
|--------|--------|---------------------------|------|
| 1      | VDD    | Power Supply 3.3V nominal | 2)   |
| 2      | VDD    | Power Supply 3.3V nominal | 2)   |
| 3      | VSS    | Ground                    | 1)   |
| 4      | VSS    | Ground                    | 1)   |
| 5      | Rin0-  | Receiver Signal (-)       |      |
| 6      | Rin0+  | Receiver Signal (+)       |      |
| 7      | VSS    | Ground                    | 1)   |
| 8      | Rin1-  | Receiver Signal (-)       |      |
| 9      | Rin1+  | Receiver Signal (+)       |      |
| 10     | VSS    | Ground                    | 1)   |
| 11     | Rin2-  | Receiver Signal (-)       |      |
| 12     | Rin2+  | Receiver Signal (+)       |      |
| 13     | VSS    | Ground                    | 1)   |
| 14     | CLK-   | Clock Signal (-)          |      |
| 15     | CLK+   | Clock Signal (+)          |      |
| 16     | VSS    | Ground                    | 1)   |
| 17     | --     | --                        | 3)   |
| 18     | --     | --                        | 3)   |
| 19     | VSS    | Ground                    | 1)   |
| 20     | VSS    | Ground                    | 1)   |

Note 1) All Vss pins should be connected to GND(0V).

Metal bezel is connected internally to Vss.

2) All Vdd pins should be connected to +3.3V.

3) Keep Open. Using these pins is prohibited.

### (2) BACK-LIGHT UNIT

CN2 《JST : BHSR-02VS-1》

| Pin No | SYMBOL         | DESCRIPTION  |
|--------|----------------|--------------|
| 1      | V <sub>L</sub> | Power Supply |
| 2      | GND            | GND (0V)     |

# LVDS INTERFACE

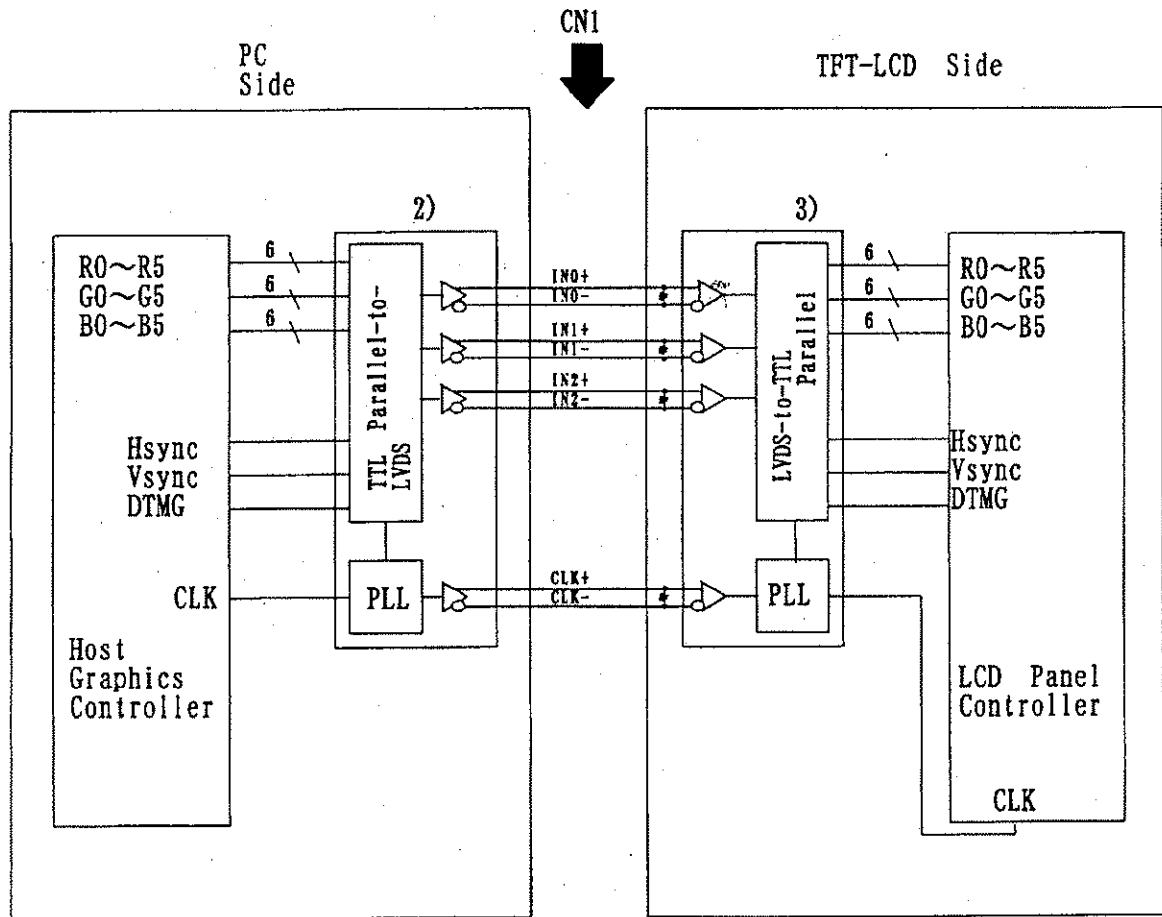

- NOTE: 1) LVDS cable impedance is 100 ohms per signal line when two are used differentially...
- 2) Transmitter : NS DS90CF363A, or equivalent.  
Transmitter is not contained in Module.
- 3) Receiver : Thine THC63LVDD64A, or equivalent

# LVDS Input Signal

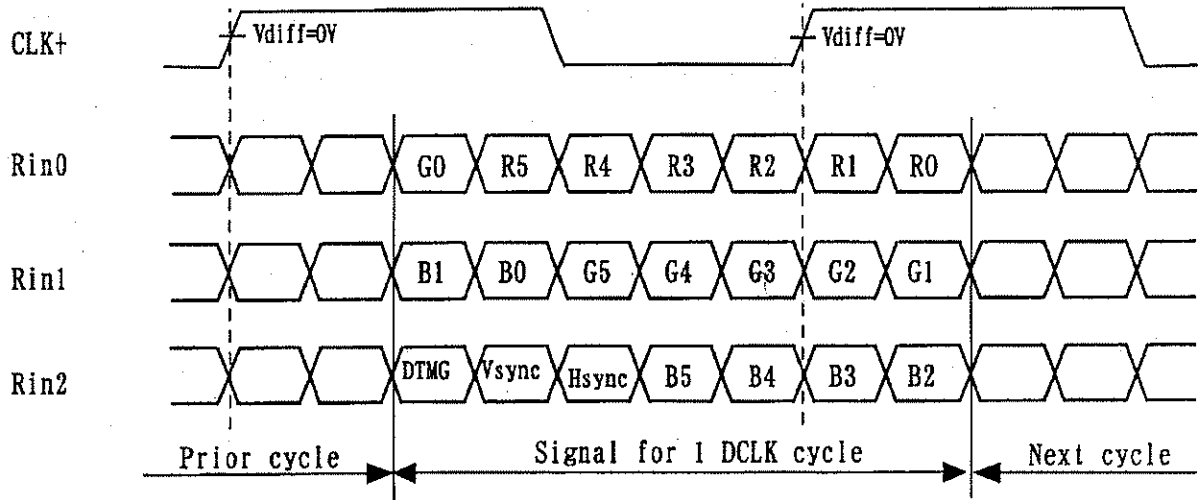

$CLK = (CLK+) - (CLK-)$   
 $RinX = (RinX+) - (RinX-)$  (X=0, 1, 2)  
 Pin connection in case of using  
 NS DS90CF363A

| Input signal | Transmitter   |
|--------------|---------------|
| CLK          | Tx CLK IN(26) |
| R0           | Tx IN0(44)    |
| R1           | Tx IN1(45)    |
| R2           | Tx IN2(47)    |
| R3           | Tx IN3(48)    |
| R4           | Tx IN4(1)     |
| R5           | Tx IN5(3)     |
| G0           | Tx IN6(4)     |
| G1           | Tx IN7(6)     |
| G2           | Tx IN8(7)     |
| G3           | Tx IN9(9)     |
| G4           | Tx IN10(10)   |
| G5           | Tx IN11(12)   |
| B0           | Tx IN12(13)   |
| B1           | Tx IN13(15)   |
| B2           | Tx IN14(16)   |
| B3           | Tx IN15(18)   |
| B4           | Tx IN16(19)   |
| B5           | Tx IN17(20)   |
| Hsync        | Tx IN18(22)   |
| Vsync        | Tx IN19(23)   |
| DTMG         | Tx IN20(25)   |

1) ( ) indicate pin NO (IC).

## 6. Interface timing

### (1) LVDS receiver timing (Interface of TFT module)

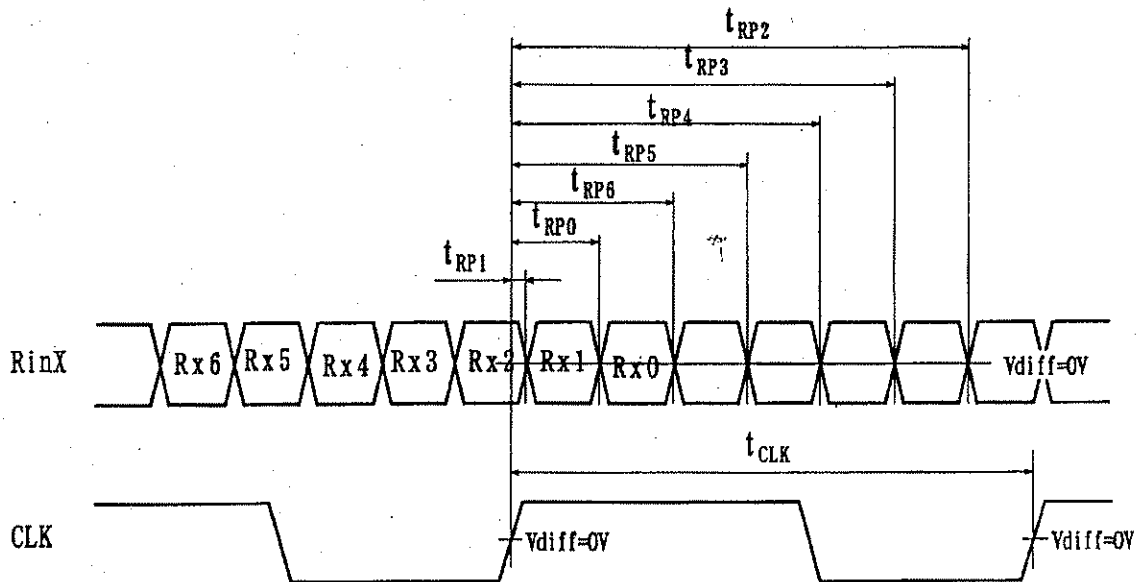

$$R_{inX} = (R_{inX+}) - (R_{inX-}) \quad (X=0, 1, 2)$$

$$CLK = (CLK+) - (CLK-)$$

| ITEM                         | SIMBOL            | MIN.        | TYP.                      | MAX.                 | UNIT                      | NOTE |
|------------------------------|-------------------|-------------|---------------------------|----------------------|---------------------------|------|
| DCLK                         | FREQUENCY         | $1/t_{CLK}$ | 60                        | 65                   | 68                        | MHz  |
| $R_{inX}$<br>( $X=0, 1, 2$ ) | 0 data position   | $t_{RP1}$   | -0.50                     | 0                    | +0.50                     | ns   |
|                              | 1st data position | $t_{RP0}$   | $\frac{1}{7}t_{CLK}-0.50$ | $\frac{1}{7}t_{CLK}$ | $\frac{1}{7}t_{CLK}+0.50$ |      |
|                              | 2nd data position | $t_{RP6}$   | $\frac{2}{7}t_{CLK}-0.50$ | $\frac{2}{7}t_{CLK}$ | $\frac{2}{7}t_{CLK}+0.50$ |      |
|                              | 3rd data position | $t_{RP5}$   | $\frac{3}{7}t_{CLK}-0.50$ | $\frac{3}{7}t_{CLK}$ | $\frac{3}{7}t_{CLK}+0.50$ |      |
|                              | 4th data position | $t_{RP4}$   | $\frac{4}{7}t_{CLK}-0.50$ | $\frac{4}{7}t_{CLK}$ | $\frac{4}{7}t_{CLK}+0.50$ |      |
|                              | 5th data position | $t_{RP3}$   | $\frac{5}{7}t_{CLK}-0.50$ | $\frac{5}{7}t_{CLK}$ | $\frac{5}{7}t_{CLK}+0.50$ |      |
|                              | 6th data position | $t_{RP2}$   | $\frac{6}{7}t_{CLK}-0.50$ | $\frac{6}{7}t_{CLK}$ | $\frac{6}{7}t_{CLK}+0.50$ |      |

(2) Timing converter timing  
(Input timing for transmitter)

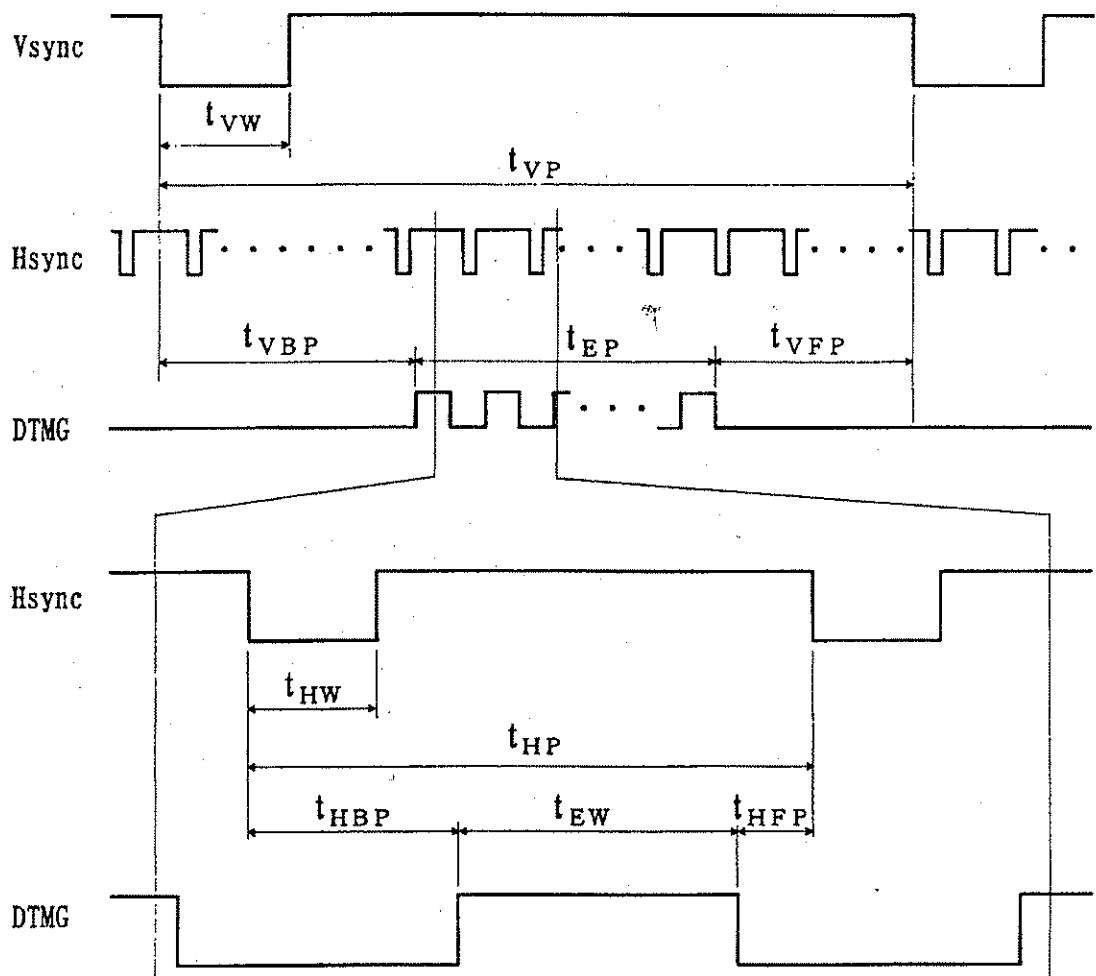

| Item  |                        | Symbol    | Min. | Typ. | Max. | Unit      | Note |
|-------|------------------------|-----------|------|------|------|-----------|------|
| Vsync | Period                 | $t_{vp}$  | 770  | —    | 1000 | $t_{HP}$  |      |
|       | Width-Active           | $t_{vw}$  | 1    | —    | 120  |           |      |
| Hsync | Period                 | $t_{hp}$  | 1180 | —    | 2400 | $t_{CLK}$ |      |
|       | Width-Active           | $t_{hw}$  | 8    | —    | 240  |           |      |
| DTMG  | Period                 | $t_{ep}$  | 768  | 768  | 768  | $t_{HP}$  |      |
|       | Width-Active           | $t_{ew}$  | 1024 | 1024 | 1024 | $t_{CLK}$ |      |
|       | Vertical Back Porch    | $t_{vbp}$ | 0    | —    | —    | $t_{HP}$  | 1)   |
|       | Vertical Front Porch   | $t_{vfp}$ | 1    | —    | —    |           |      |
|       | Horizontal Back Porch  | $t_{hbp}$ | 32   | —    | 416  | $t_{CLK}$ |      |
|       | Horizontal Front Porch | $t_{hfp}$ | 4    | —    | —    |           |      |

NOTE 1)  $t_{vbp} + t_{vfp} \geq 2$

(3) TIMING BETWEEN INTERFACE SIGNAL AND POWER SUPPLY

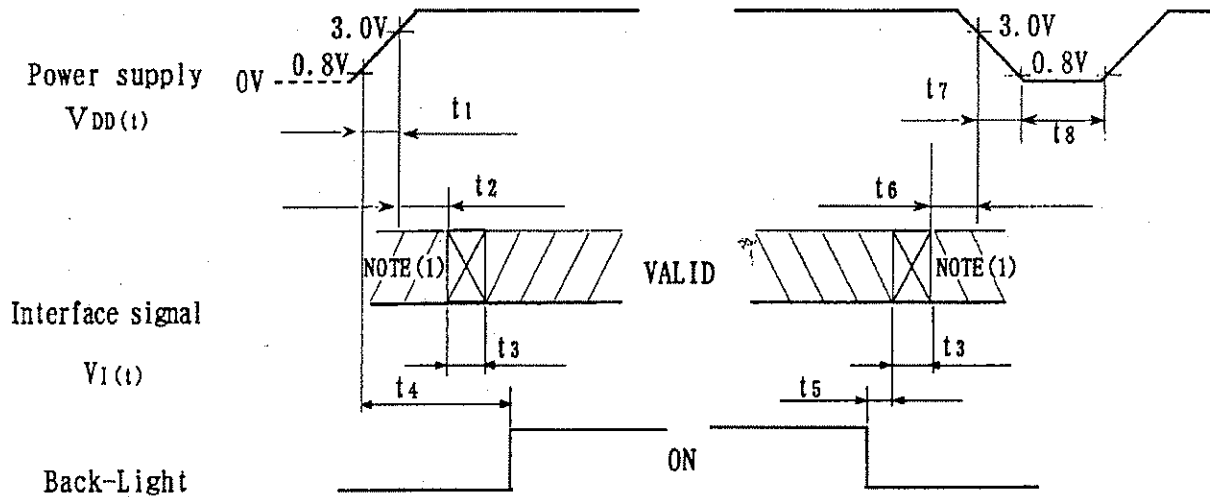

POWER ON  
 $t_1 \leq 15\text{ms}$   
 $0 < t_2 \leq 45\text{ms}$   
 $0 \leq t_3 \leq 5\text{ms}$   
 $0.1\text{s} \leq t_4$  NOTE (3)

POWER OFF  
 $5\text{ms} \leq t_5$   
 $0 \leq t_6 \leq 45\text{ms}$   
 $0 \leq t_7 \leq 20\text{ms}$   
 $0.4\text{s} \leq t_8$

NOTE (1)  $t_2$ : Hi-Z (Hi-impedance) state

(2)  $t_3$ : Signal transition time from Hi-Z state to Valid state specified by 3(1), 6(1) and (2).

(3) Recommended value

7. DIMENSIONAL OUTLINE

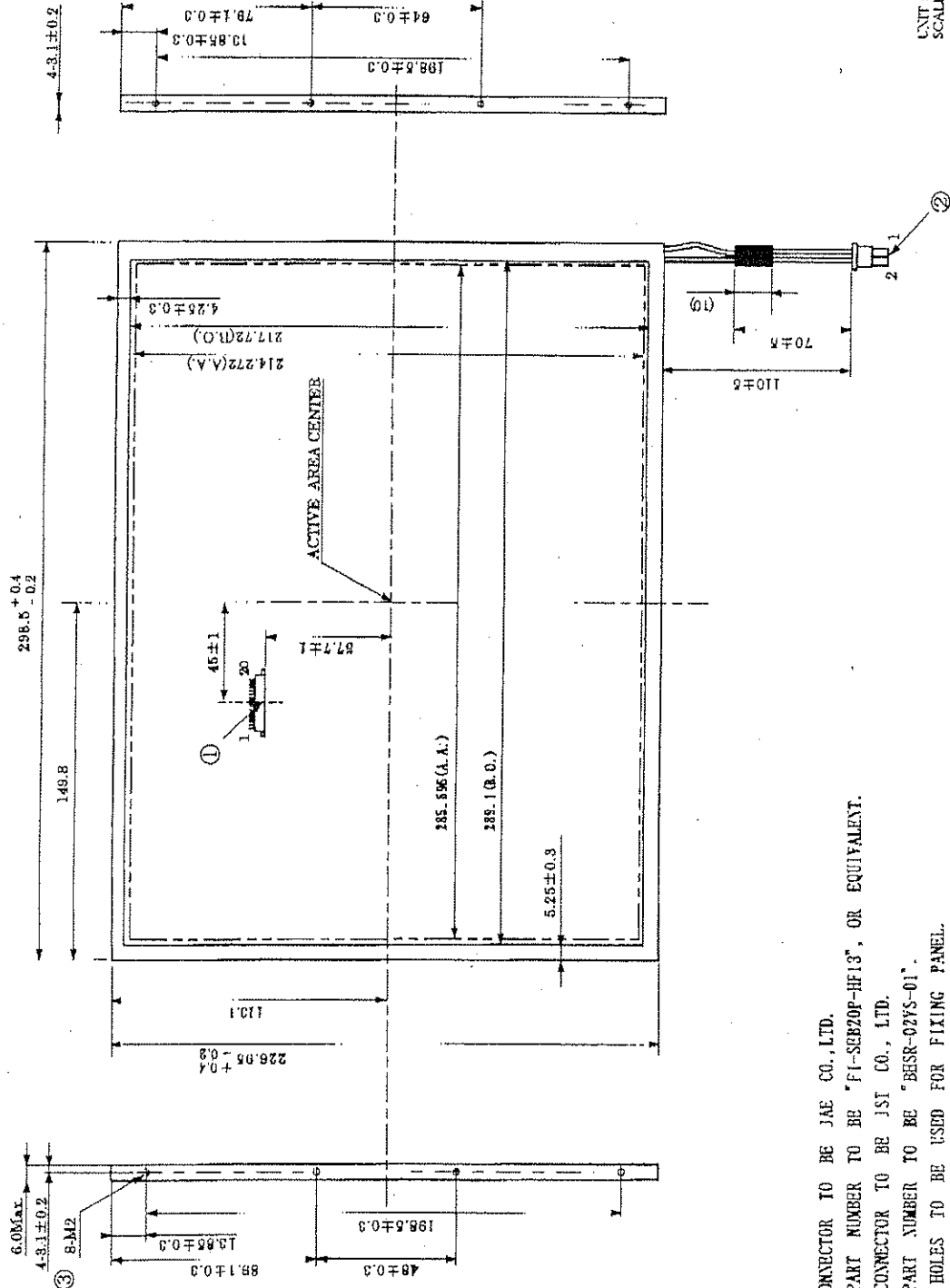

UNIT : mm  
SCALE : NTS

NOTES

- ① I/F CONNECTOR TO BE JAE CO., LTD.
- ② THIS PART NUMBER TO BE "F1-SEB20P-HF13", OR EQUIVALENT.
- ③ LAMP CONNECTOR TO BE JST CO., LTD.
- ④ THIS PART NUMBER TO BE "BESR-02FS-01".
- ⑤ THESE HOLES TO BE USED FOR FIXING PANEL.
- ⑥ THE UNSPECIFIED TOLERANCE : ±0.5mm
- ⑦ MAXIMUM TORQUE FOR THE SCREW IN MOUNTING PANEL : 0.147N·m
- ⑧ MAXIMUM LENGTH OF SCREW FOR TFT MODULE MOUNTING : 2.2mm