



ELECTRONICS

Product Information

ISSUE DATE : 2003-03-25

MODEL : LTM170EU-A01

Note : This Product information is subject to change after 3 months of issuing date

Prepared by AMLCD Technical Customer Service Team

Samsung Electronics Co . , LTD.

Contents

1. General Description	-----	3
2. Electrical Absolute Ratings	-----	5
3. Environmental Specification	-----	5
4. Optical Characteristics	-----	6
5. Electrical Specification		
5.1 Input video and sync signal	-----	7
5.2 Input Signal Pin Assignment	-----	8
5.3 Function Key Pin Assignment and Description	-----	8
5.4 Power Supply	-----	9
5.4.1 Pin Assignment and description	-----	9
5.4.2 Input voltage & Rush current	-----	9
5.4.3 DPMS: VESA DPMS compliance	-----	9
5.5 Power Consumption	-----	9
5.5.1 Measurement of power consumption	-----	9
5.5.2 Power management mode: VESA DPMS protocol applied	-----	10
6. User Interface	-----	11
6.1 OSD Key Matrix	-----	11
6.2 User Controls	-----	11
7. Mechanical Specification		
7.1 Outline dimension	-----	12
7.2 Packing Information	-----	13
8. GENERAL PRECAUTION	-----	15
8.1 Handling	-----	15
8.2 Storage	-----	15
8.3 Operation	-----	15
8.4 Others	-----	16

1. General Description

LTM170EU-A01 is a new concept of System-On-Panel (SOP) display device. It provides total and high quality TFT-LCD display solutions for customer system design. Customer can use the high quality display unit just like an integrated circuit (IC).

As ICs are used as building blocks of many complicated electronic systems, this new display solution can be used just same.

This device includes the high quality TFT-LCD panel and the high brightness 4-lamp backlight unit with the optimized inverter. Integrated signal processing unit, named LSP (LCD Signal Processor™), includes all electronic function for user application. It includes analog-to-digital conversion, Scaling, OSD, EDID (DDC 2 compliance) and LCD Timing controller. More functions are available, also. World-top notebook LCD design technology of Samsung realize the most compact solution. Customer can enjoy wide system design flexibility.

EMI is the additional point of this device. All of the units are shielded by metal case finally.

* Features

- High display quality : High contrast ratio, Wide-viewing angle and High-speed response time.
- High brightness with the 4-CCFL backlight lamps using optimized inverter.
- On Screen Display(OSD): Samsung generic bitmap OSD is supported, but the customized OSD is also available using system development tool.
- Digital Image Processor is embedded with intelligent microprocessor.
- Wide Input Voltage Range : +10VDC +15VDC
- DDC Ver. 2 Compliance by system integrator
- VESA DPMS compliance
- Low Power Consumption
- Easier EMI troubleshooting and solution supported.
- Easy Lamp replacement

* Information

Items	Specification	Unit	Note
Display area	337.92(H) x 270.336(V)	mm	17.0 inch diagonal
Driver element	a-Si TFT active matrix		
Display colors	16.2M (true)	colors	6-bit FRC
Number of pixels	1280x1024	pixel	
Pixel arrangement	RGB vertical stripe		
Pixel pitch	0.264(H) x 0.264(W)	mm	
Display mode	Normally White		
Surface treatment	Haze 25% , Hard-coating (3H)		
Backlight	4 Lamps		

* Explanation for Product code

L T M 1 7 0 E U - A01 - _ _ _

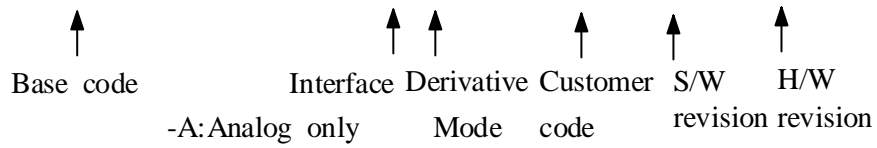

* System Block Diagram

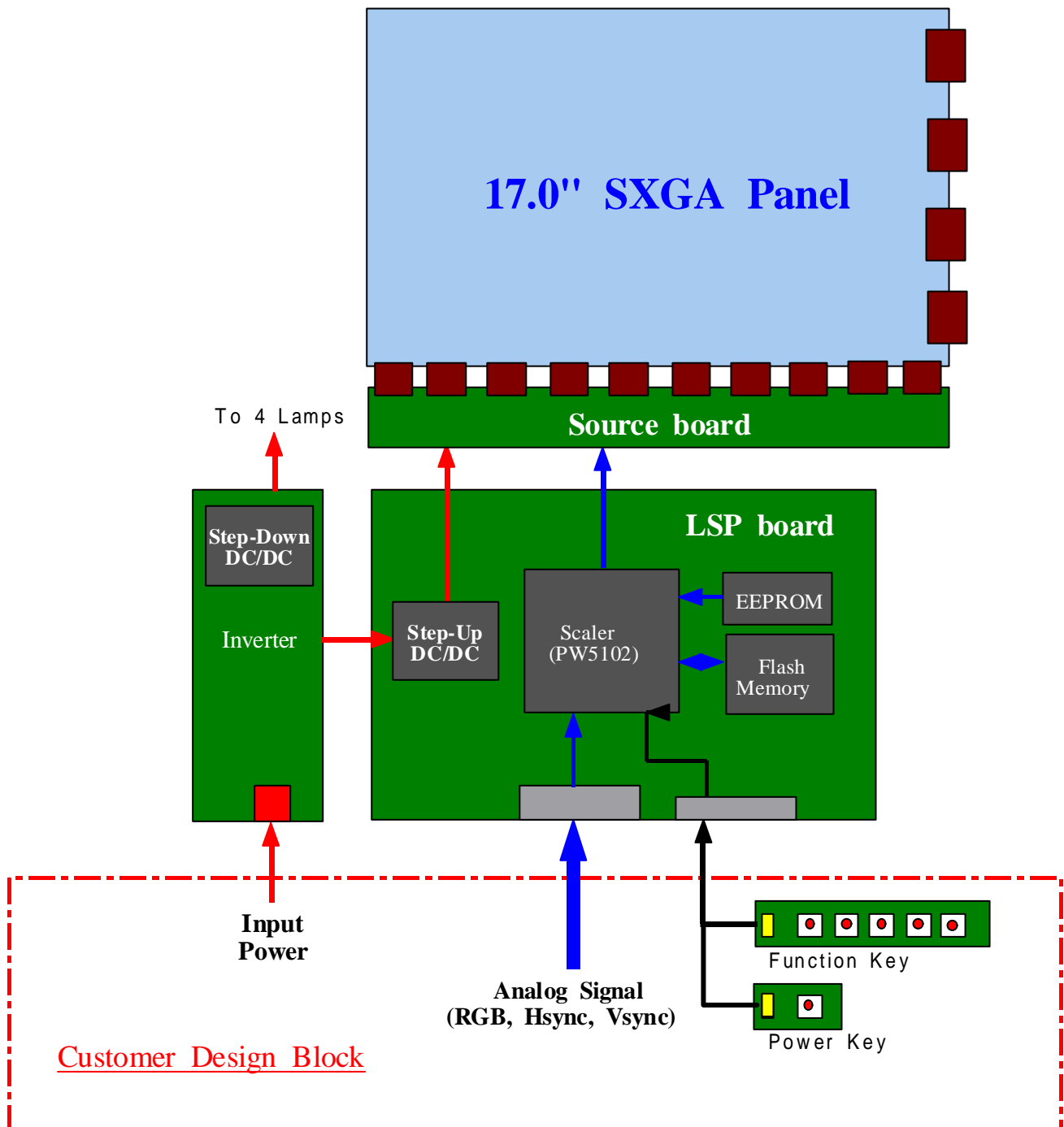

*** Mechanical information**

Item		Min	Typ	Max	Note
Module size	Horizontal(H)	358	358.5	359	mm
	Vertical(V)	296	296.5	297	mm
	Depth(D)	-	-	22	mm
Weight		-	-	2200	g

2. Electrical Absolute Ratings

(1) TFT LCD Module

(V_{SS} = GND = 0 V)

Item	Symbol	Min	Max	Unit	Note
Power Supply Voltage	VDD	-0.3	+21	V	(1)

NOTE (1) Within Ta (25 ± 2 °C)

3. Environmental Specification

Items	Min.	Max.	Units	Note
Storage Temperature	-25	+60		
Operating Temperature	0	+50		
Shock (Non-operating)	-	50	G	11ms, 1 time for ±X, ±Y, ±Z
Vibration (Non-operating)	-	1.5	G	10-300Hz, Sweep rate:10min, 30min for X, Y, Z axis

Note: If this product is used for extended time excessively or exposed to high temperatures for extended time, there is a possibility of wide viewing angle film damage which could affect visual characteristics.

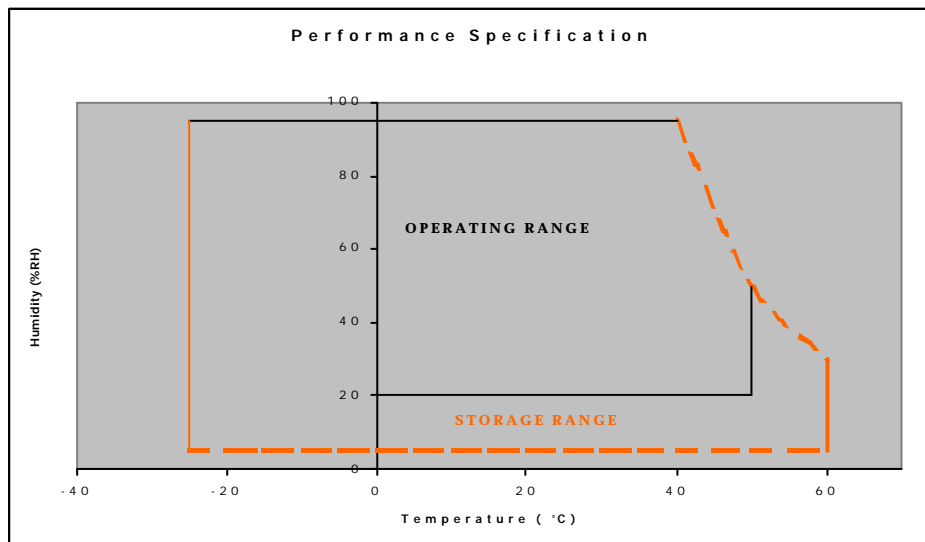

4. Optical Characteristics

The following items are measured under stable conditions. The optical characteristics should be measured

in a dark room or equivalent state with the methods shown in Note (1).

Measuring equipment : TOPCON BM-5A: Contrast Ratio, Luminance of White, Viewing Angle

TOPCON BM-7: Response time

Photo Research PR650: Color Chromaticity

$T_a = 25 \pm 2$, $V_{IN} = +12V$, $f_v = 60Hz$

Item	Symbol	Condition	Min	Typ	Max	Unit	Note	
Contrast Ratio	CR	=0, =0 Normal Viewing Angle	250	-	-		(1),(2),(4)	
Response Time at T_a	Rising		T_r	-	5	-	msec	(1),(3)
	Falling		T_f	-	20	-		
Luminance of White (Center of Screen)	Y_L			230	270	-	cd/m^2	(1),(4)
Color Chromaticity (CIE 1931)	Red		R_x	T.B.D	0.633	T.B.D		(1), (4)
			R_y		0.351			
	Green		G_x		0.298			
			G_y		0.592			
	Blue		B_x		0.143			
			B_y		0.092			
	White	W_x	0.316					
		W_y	0.337					
Viewing Angle	Hor.	L	60	-	-	Degrees		
		R	60	-	-			
	Ver.	H	50	-	-			
		L	50	-	-			
Color Gamut			-	65	-	%		
Brightness Uniformity (9 points)	B_{UNI}		-	-	25	%	(5)	
Cross Modulation	C_T		-	-	5	%	(6)	

Measuring Condition: Maximum value of Brightness and Contrast in OSD menu.

5. Electrical Specification

5.1 Input video and sync signal

* Signal Connector : S13B-PH-SM3-TB (JST)

Mating Connector : PHR-13

Item		Description	Notes
Video	Input	<ul style="list-style-type: none"> · Type: Analog RGB · level : 0.7Vp-p ±5% · Polarity: Positive Bright · Impedance: 75 ±5% (Terminated) 	VESA Compliance
	Resolution	<ul style="list-style-type: none"> · Optimum: 1280 ×1024@60Hz · Maximum: 1280 ×1024@75Hz 	
	Horizontal Frequency	<ul style="list-style-type: none"> · 30~80KHz 	
	Vertical Frequency	<ul style="list-style-type: none"> · 55~75Hz 	
	Applicable Bandwidth	<ul style="list-style-type: none"> · Typical: 108MHz (1280x1024@60Hz) · Max: 135MHz (1280x1024@75Hz) 	
Sync	Input	<ul style="list-style-type: none"> · Type : separate H/V sync, · Level : TTL level (V high 2.0V, V low 0.8V) · Polarity : Positive or negative. 	

5.2 Input Signal Pin Assignment and Description

* Signal Connector : S13B-PH-SM3-TB (JST)

Mating Connector : PHR-13

Group	Pin No.	Pin Name	Description	Note
Analog RGB	Pin 01	DB_DET	Cable Detect Pin	Internally Pull-Up (Connect this pin with DSUB #5 pin)
	Pin 02	DB_SDA	Serial Data for DDC	
	Pin 03	DB_SCL	Serial Clock for DDC	
	Pin 04	RGND	Red Ground	
	Pin 05	DB_RED	Red Data Input	
	Pin 06	GGND	Green Ground	
	Pin 07	DB_GRN	Green Data Input	
	Pin 08	BGND	Blue Ground	
	Pin 09	DB_BLU	Blue Data Input	
	Pin 10	NC	Not used	
	Pin 11	DB_VSY	Vsync Input	
	Pin 12	SGND	Sync Ground	
	Pin 13	DB_HSY	Hsync Input	

5.3 Function Key Pin Assignment and Description

* Connector type: 53261-1490 (MOLEX)

Mating Connector: 51021-1490

Group	Pin No.	Pin Name	Description
Keypad	Pin 01	KVDD	Keypad Unit Power
	Pin 02	KGND 1	Keypad Unit Ground
	Pin 03	KEY8	Key Input #8
	Pin 04	KEY7	Key Input #7
	Pin 05	KEY6	Key Input #6
	Pin 06	KEY5	Key Input #5
	Pin 07	KEY4	Key Input #4
	Pin 08	KEY3	Key Input #3
	Pin 09	KEY2	Key Input #2
	Pin 10	KGND 2	Keypad Unit Ground
	Pin 11	KEY1	Key Input #1
	Pin 12	KGND 3	Keypad Unit Ground
	Pin 13	LED1	Status Indicator
	Pin 14	LED2	Status Indicator

5.4 Power Supply

5.4.1 Pin Assignment and description

*Connector type: 40006WR-02 (YeonHo Electronics)

Pin No.	Pin Name	Description	Note
1	Vin	Input Power, +12VDC (typ.)	
2	GND	Ground	

5.4.2 Input voltage & Rush current

Items	Symbol	Min.	Typ.	Max.	Unit
Input Volage	Vin	+10	+12	+15	V
Rush Current	Irush	-	-	+12	A

5.4.3 DPMS: VESA DPMS compliance

5.5 Power Consumption

5.5.1 Measurement of power consumption

Voltage	Current				Resolution
	Min.	Typ.	Max.	Unit	
10V	-	3.2	3.7	A	1280*1024@60Hz
12V	-	2.7	3.1	A	
15V	-	2.1	2.5	A	

Power saving(Stand-by, Suspend, Off mode): less than 3 watts. Monitor has to be recovered to normal operation mode within 4 seconds when normal signal is applied from signal source.

Maximum condition

- OSD condition : Brightness 100, Contrast 100
- test pattern : One pixel on/off (1dot) pattern

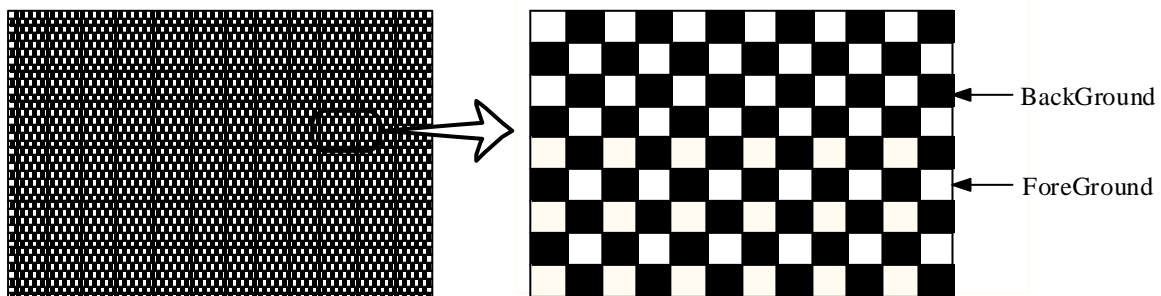

5.5.2 Power management mode: VESA DPMS protocol applied.

Mode	Horizontal sync	Vertical sync	LED1	LED2	Power consumption
On	Active	Active	Off	On	32 watts(Typ.)
Stand-by	Inactive	Active	On/Off (Blinking)	On	< 3 watts
Suspend	Active	Inactive			
Off	Inactive	Inactive			

6. User Interface

6.1 OSD Key Matrix

This table is based on OSD S/W presented by SAMSUNG.

If our customer wants their customized OSD, Key matrix will be changed.

Input Connector		Keypad
Pin No.	Pin Name	Function
Pin 01	KVDD	+3.3V / 100mA
Pin 02	KGND1	-
Pin 03	KEY8	"AUTO"
Pin 04	KEY7	EXIT
Pin 05	KEY6	"LEFT"(Brightness "-")
Pin 06	KEY5	-
Pin 07	KEY4	-
Pin 08	KEY3	"RIGHT"(Brightness "+")
Pin 09	KEY2	"MENU"
Pin 10	KGND2	
Pin 11	KEY1	"SOFT POWER"
Pin 12	KGND3	
Pin 13	LED1	LED1
Pin 14	LED2	LED2

* Firmware(including OSD) presented by SAMSUNG is edited by w3SDK 1.0

6.2 User Controls

- * Power: Turn on and off the monitor power.
- * Menu: Calls OSD menu and select the function to be adjusted.
- * Exit
Exit from the OSD function or Back to previous menu.
- * Auto
Auto adjust by press directly without OSD menu.
- * "-"
Moves the selector left on the OSD menu.
Decrease the value of selected adjustment or Select proper setting.
Brightness control by press directly without OSD menu.
- * "+"
Moves the selector right on the OSD menu.
Increase the value of selected adjustment or Select proper setting.
Brightness control by press directly without OSD menu.
- * LED: Indicates the status of monitor operation.
LED2: Normal
Black: Power OFF
LED1: Power saving mode or Disconnection of signal cable.
- * Service key
Software Information -> Press "EXIT" & "-" during 2 secs
Backlight Hours -> Press "-" & "+" during 2 secs

7.MechanicalSpecification

7.1 Outline dimension

Nest page

NO	PART NAME	CODE NO	SPECIFICATION	Q'TY	WEIGHT		UNFOLDED DIM. OF MATERIAL	REMARK
					FINISH	MATERIAL		

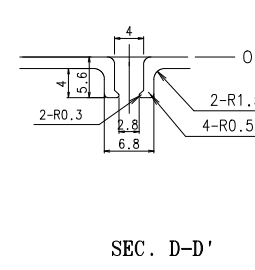
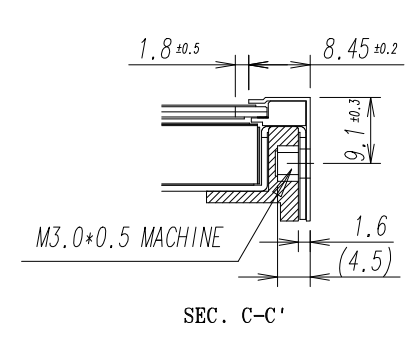
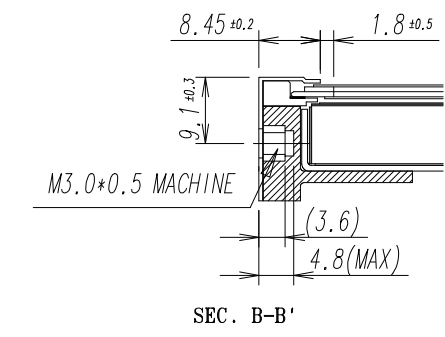
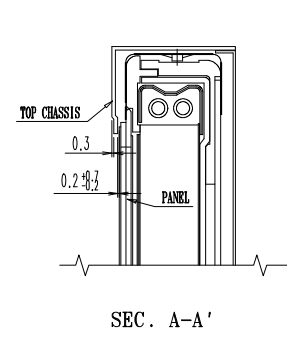
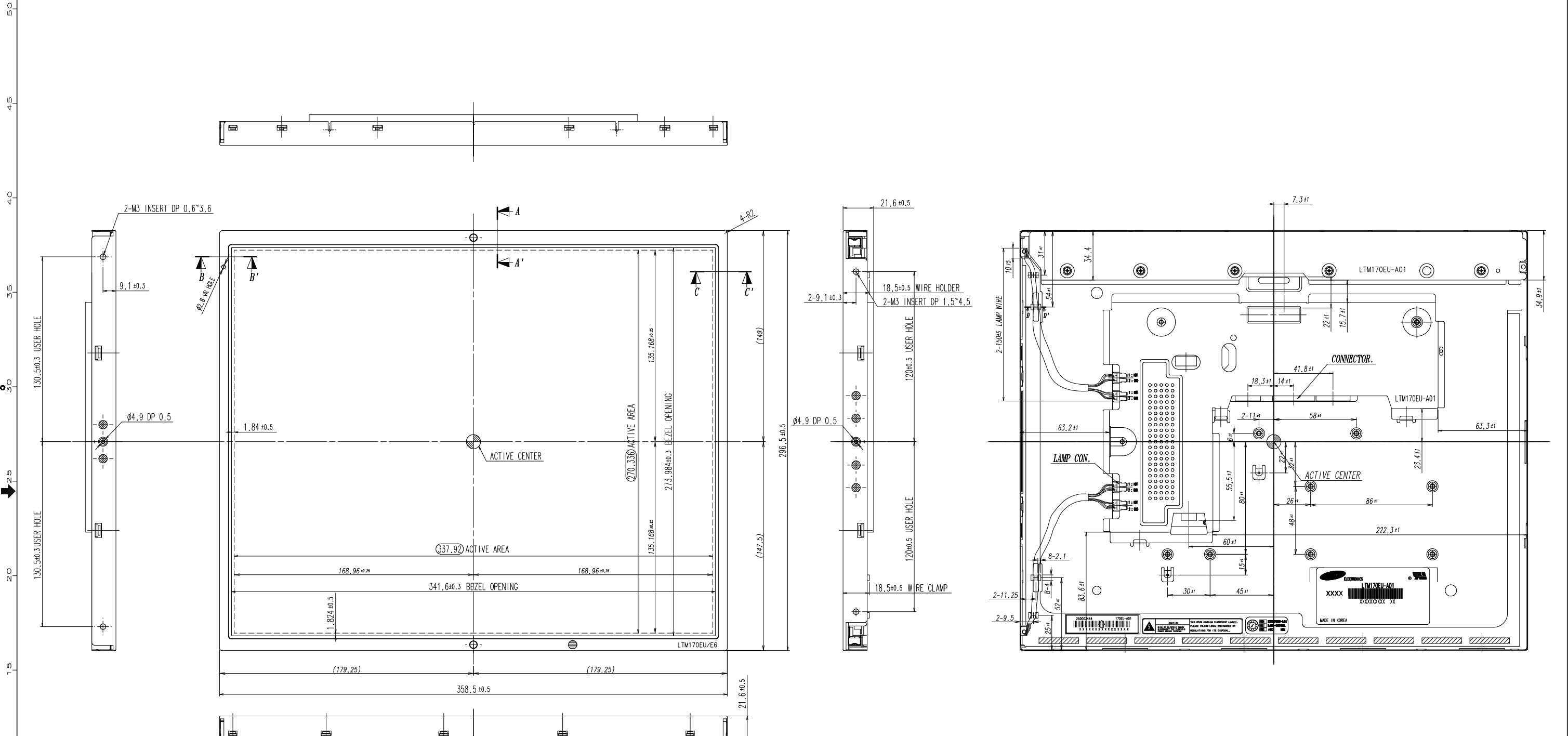

- * NOTES**
- BACKLIGHT : 4 COLD CATHODE FLUORESCENT LAMPS.
 - 1/ F CONNECTOR SPECIFICATION.
 - MAKER : JAE
 - PART NO : F1-X30S-HF
 - LAMP CONNECTOR/WIRE SPECIFICATION.
 - MAKER : JST
 - PART NO : BHSR-02VS-1(2 PIN x 145mm)
 - ALLOWED DEPTH OF USERHOLE SCREW INSERTION IS 4.8MM MAX
 - USER MOUNTING TORQUE SPEC:7Kgf-Cm

REVISION	GENERAL TOLERANCE				REV	DATE	DESCRIPTION OF REVISION				REASON		CHG'D BY
	STEP	LEVEL 1	LEVEL 2	LEVEL 3	UNIT	DRAWN BY	DES'D BY	CHK'D BY	APP'D BY	MODEL NAME	LTM170EU-A01	CHG'D BY	
	0 < X ≤ 4	±0.05	±0.1	±0.2	mm	S. Y. KANG	Y. G. WON	J. D. PARK			PART/SHEET NAME	OUTLINE DIM.	SHEET 1 / 1
	4 < X ≤ 16	±0.08	±0.15	±0.3	TOLERANCE	.03.DT.2#		03.01.24	03.01.24	SPEC. NO			VER. 01
16 < X ≤ 64	±0.12	±0.25	±0.5	SAMSUNG ELECTRONICS									
64 < X ≤ 256	±0.25	±0.4	±0.8										

7.2 Packing Information

8.2.1 Carton (Internal Package)

8.2.1.1 Packing Form: Corrugated fiberboard box and corrugated cardboard as shock absorber.

8.2.1.2 Packing Method

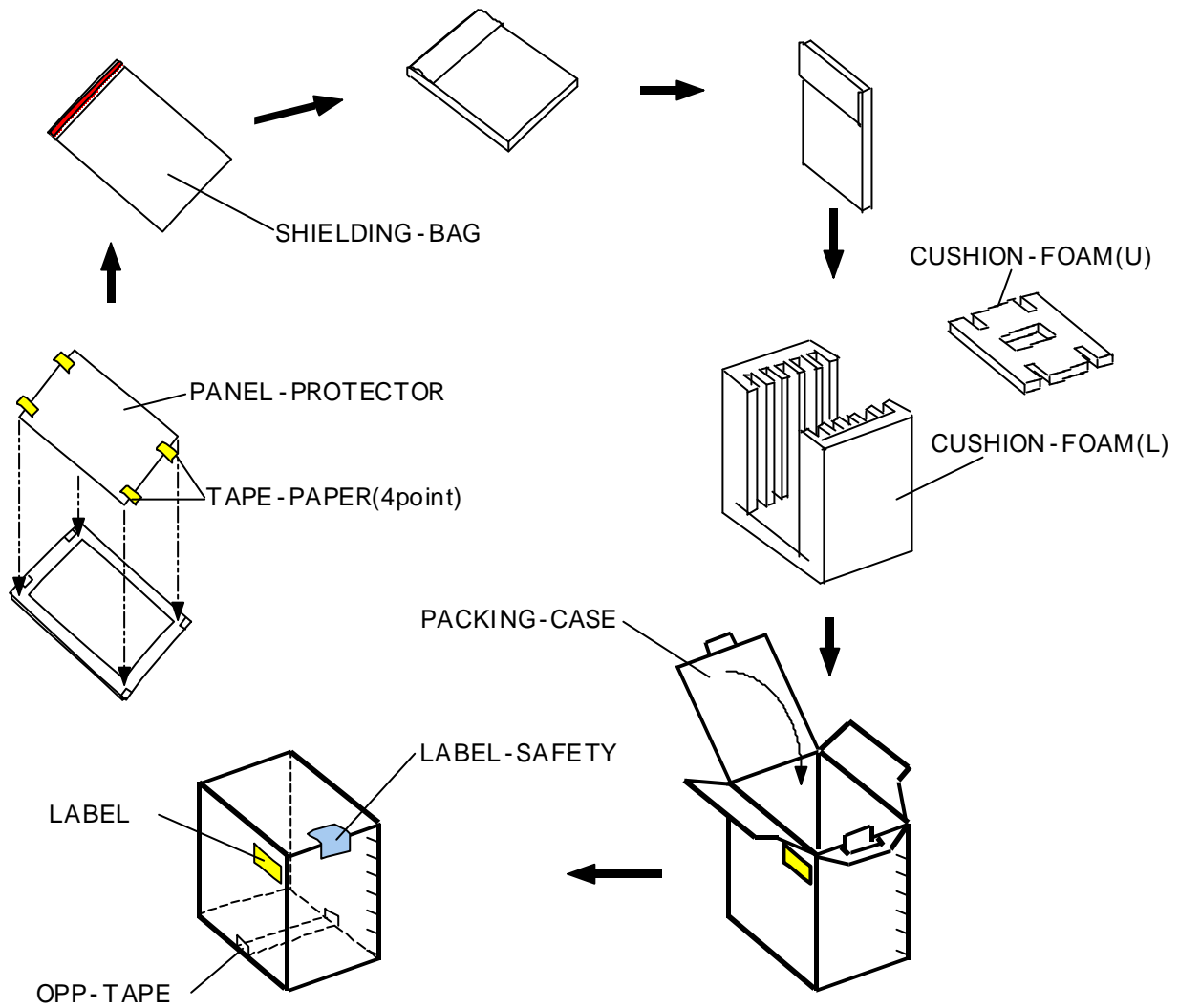

- NOTE 1) Acceptance number of piling : 5sets
2) Carton size :401(W) X 365(D) X 477(H)
3) MAX accumulation quantity : 5 cartons

7.2.1.3 Packing Material

No	Part name	Quality
1	Static electric protective sack	5
2	Packing case(Inner box) included shock absorber	1 set
3	Pictorial marking	2 pcs
4	Carton	1 set

8. GENERAL PRECAUTION

8.1 Handling

When the module is assembled, It should be attached to the system firmly using every mounting holes. Be careful not to twist and bend the modules.

Refrain from strong mechanical shock and / or any force to the module. In addition to damage, this may cause improper operation or damage to the module and CCFT back-light.

Note that polarizers are very fragile and could be easily damaged. Do not press or scratch the surface harder than a HB pencil lead.

Wipe off water droplets or oil immediately. If you leave the droplets for a long time, Staining and discoloration may occur.

If the surface of the polarizer is dirty, clean it using some absorbent cotton or soft cloth. The desirable cleaners are water, IPA(Isopropyl Alcohol) or Hexane. Do not use Ketone type materials (ex. Acetone), Ethyl alcohol, Toluene, Ethyl acid or Methyl chloride. It might permanent damage to the polarizer due to chemical reaction.

If the liquid crystal material leaks from the panel, it should be kept away from the eyes or mouth . In case of contact with hands, legs or clothes, it must be washed away thoroughly with soap.

Protect the module from static , it may cause damage to the CMOS IC.

Use finger-stalls with soft gloves in order to keep display clean during the incoming inspection and assembly process.

Do not disassemble the module.

Do not pull or fold the lamp wire.

Do not adjust the variable resistor which is located on the back side.

Pins of I/F connector shall not be touched directly with bare hands.

8.2 Storage

Do not leave the module in high temperature, and high humidity for a long time.

It is highly recommended to store the module with temperature from 0°C to 35°C and relative humidity of less than 70%.

Do not store the TFT-LCD module in direct sunlight.

The module shall be stored in a dark place. It is prohibited to apply sunlight or fluorescent light during the store.

8.3 Operation

Do not connect,disconnect the module in the Power On condition.

Module has high frequency circuits. Sufficient suppression to the electromagnetic interference shall be done by system manufacturers. Grounding and shielding methods may be important to minimize the interference.

8.4 Others

Ultra-violet ray filter is necessary for outdoor operation.

Avoid condensation of water. It may result in improper operation or disconnection of electrode. Do not exceed the absolute maximum rating value. (the supply voltage variation, input voltage variation, variation in part contents and environmental temperature, so on) Otherwise the module may be damaged.

If the module displays the same pattern continuously for a long period of time, it can be the situation when the image sticks to the screen.

This module has its circuitry PCB on the rear side and should be handled carefully in order not to be stressed.