

APREPARED BY : DATE	 DISPLAY DEVICE BUSINESS GROUP SHARP CORPORATION  SPECIFICATION	SPEC No. LD-23805D
APPROVED BY : DATE		FILE No.
		ISSUE : Aug. 12. 2011
		PAGE : 24pages
		APPLICABLE GROUP DISPLAY DEVICE BUSINESS GROUP

Revised: Mar. 2.2012

DEVICE SPECIFICATION FOR  
**TFT-LCD Module**  
 MODEL No.  
**LQ101K1LY04**

CUSTOMER'S APPROVAL

DATE \_\_\_\_\_

BY \_\_\_\_\_

PRESENTED

BY *J. Kawanishi*

J.KAWANISHI

Department General Manager

Development Dept. I

DISPLAY DEVICE DIVISION II

DISPLAY DEVICE BUSINESS GROUP

SHARP CORPORATION



**NOTICE**

This publication is the proprietary of SHARP and is copyrighted, with all rights reserved. Under the copyright laws, no part of this publication may be reproduced or transmitted in any form or by any means, electronic or mechanical for any purpose, in whole or in part, without the express written permission of SHARP. Express written permission is also required before any use of this publication may be made by a third party.

The application circuit examples in this publication are provided to explain the representative applications of SHARP's devices and are not intended to guarantee any circuit design or permit any industrial property right or other rights to be executed. SHARP takes no responsibility for any problems related to any industrial property right or a third party resulting from the use of SHARP's devices, except for those resulting directly from device manufacturing processes.

In the absence of confirmation by device specification sheets, SHARP takes no responsibility for any defects that occur in equipment using any of SHARP's devices, shown in catalogs, data books, etc. Contact SHARP in order to obtain the latest device specification sheets before using any SHARP's device.

SHARP reserves the right to make changes in the specifications, characteristics, data, materials, structures and other contents described herein at any time without notice in order to improve design or reliability. Contact SHARP in order to obtain the latest specification sheets before using any SHARP's device. Manufacturing locations are also subject to change without notice.

Observe the following points when using any device in this publication. SHARP takes no responsibility for damage caused by improper use of the devices.

The devices in this publication are designed for general electronic equipment use.

The appropriate design measures should be taken to ensure reliability and safety when SHARP's devices are used for equipment such as:

- Transportation control and safety equipment (i.e., aircraft, trains, automobiles, etc.)
- Traffic signals • Gas leakage sensor breakers • Alarm equipment • Various safety devices etc.

SHARP's devices shall not be used for equipment that requires extremely high level of reliability, such as:

- Military and space applications • Nuclear power control equipment
- Medical equipment for life support

Contact a SHARP representative, in advance, when intending to use SHARP's devices for any "specific" applications other than those recommended by SHARP.

Contact and consult with a SHARP representative if there are any questions about the contents of this publication.

Table of contents 

1. Application .....	3
2. Overview .....	3
3. Mechanical Specifications .....	3
4. Input Terminals .....	4
4 - 1. Symbol .....	4
4 - 2. LVDS interface block diagram .....	6
5. Absolute Maximum Ratings .....	7
6. Electrical Characteristics .....	8
6 - 1. TFT-LCD panel driving .....	8
6 - 2. LVDS input specification.....	10
6 - 2 - 1. AC characteristics .....	10
6 - 2 - 2. LVDS data .....	11
6 - 3. Backlight driving .....	11
7. Timing Characteristics of Input Signals.....	12
7 - 1. Timing characteristics .....	12
7 - 2. Input data signals and display position on the screen .....	13
8. Input Signals, Basic Display Colors and Gray Scale of Each Color .....	14
9. Optical Characteristics .....	15
10. Display Quality .....	16
11. Handling Precautions .....	17
12. Packaging Condition .....	18
13. Label.....	19
14. RoHS Directive .....	19
15. Reliability Test Items .....	20
Fig. 1 Packing Form .....	21
Fig. 2 Outline Dimensions .....	22

### 1. Application

This specification applies to a color TFT-LCD module, LQ101K1LY04.

### 2. Overview

This module is a color active matrix LCD module incorporating amorphous silicon TFT (Thin Film Transistor). It is composed of a color TFT-LCD panel, driver ICs, a control circuit and power supply circuit, and a backlight unit. Graphics and texts can be displayed on a 1280×3×800 dots panel with (16,777,216) colors by using LVDS (Low Voltage Differential Signaling) to interface and supplying +3.3V DC supply voltage for TFT-LCD panel driving and supply voltage for backlight.

In this TFT-LCD panel, color filters for excellent color performance and backlights for high brightness are incorporated to realize brighter and clearer pictures, making this model optimum for use in multi-media applications.

Optimum viewings are in all directions.

Backlight-driving LED controller is not built in this module.

### 3. Mechanical Specifications

Parameter	Specifications	Unit
Display size	25.6 (10.07") Diagonal	cm
Active area	217.0 (H)×135.6 (V)	mm
Pixel format	1280 (H)×800 (V)	pixel
	(1 pixel = R+G+B dots)	
Pixel pitch	0.170 (H)×0.170 (V)	mm
Pixel configuration	R,G,B vertical stripe	
Display mode	Normally black	
Surface treatment	Glare + LR	
Dimension*	229.46(W) x 149.1(H) x 4.8(D)	mm
Mass	Typ.165/Max .185	g

[Note 3-1] Outline dimensions is shown in Fig.2

## 4. Input Terminals

## 4 - 1. Symbol

△<sub>2</sub> CN1 (LVDS signals, +3.3V DC power supply, and B/L power supply)

Pin No.	Symbol	Function	Remark
1	NC		[Note4-1-2]
2	VDD	+3.3V power supply	
3	VDD	+3.3V power supply	
4	NC		[Note4-1-2]
5	NC		[Note4-1-2]
6	NC		[Note4-1-2]
7	NC		[Note4-1-2]
8	RIN0-	Receiver signal of LVDS CH0(-)	[Note4-1-1]
9	RIN0+	Receiver signal of LVDS CH0(+)	[Note4-1-1]
10	GND	GND	
11	RIN1-	Receiver signal of LVDS CH1(-)	[Note4-1-1]
12	RIN1+	Receiver signal of LVDS CH1(+)	[Note4-1-1]
13	GND	GND	
14	RIN2-	Receiver signal of LVDS CH2(-)	[Note4-1-1]
15	RIN2+	Receiver signal of LVDS CH2(+)	[Note4-1-1]
16	GND	GND	
17	RCLK-	Receiver signal of LVDS CLK(-)	[Note4-1-1]
18	RCLK+	Receiver signal of LVDS CLK(+)	[Note4-1-1]
19	GND	GND	
20	RIN3-	Receiver signal of LVDS CH3(-)	[Note4-1-1]
21	RIN3+	Receiver signal of LVDS CH3(+)	[Note4-1-1]
22	GND	GND	
23	NC		[Note4-1-2]
24	NC		[Note4-1-2]
25	GND	GND	
26	NC		[Note4-1-2]
27	NC		[Note4-1-2]
28	NC		[Note4-1-2]
29	NC		[Note4-1-2]
30	NC		[Note4-1-2]
31	NC		[Note4-1-2]
32	LED_C1	LED_Cathode1	
33	LED_C2	LED_Cathode2	
34	LED_C3	LED_Cathode3	
35	LED_C4	LED_Cathode4	
36	LED_C5	LED_Cathode5	
37	LED_C6	LED_Cathode6	
38	NC		[Note4-1-2]
39	LED_A	LED_Anode	
40	LED_A	LED_Anode	

[Note 4-1-1] Relation between  $RIN_i(i=0,1,2,3)$  and actual data is shown in following section (4-2)(6-2).

[Note 4-1-2] Don't input any signals or any powers into a NC pin. Keep the NC pin open.

[Note 4-1-3] The shielding case is connected with signal GND.

- Connector used : (20455-040E-12 (I-PEX))
- Corresponding connector : (20453-040T-01 (I-PEX))

(Sharp is not responsible to its product quality, if the user applies a connector not corresponding to the above model.)

4 - 2. LVDS interface block diagram

Receiver used: Single LVDS interface contained in a control IC

Corresponding Transmitter : THC63LVDM83D (THINE) or equivalent

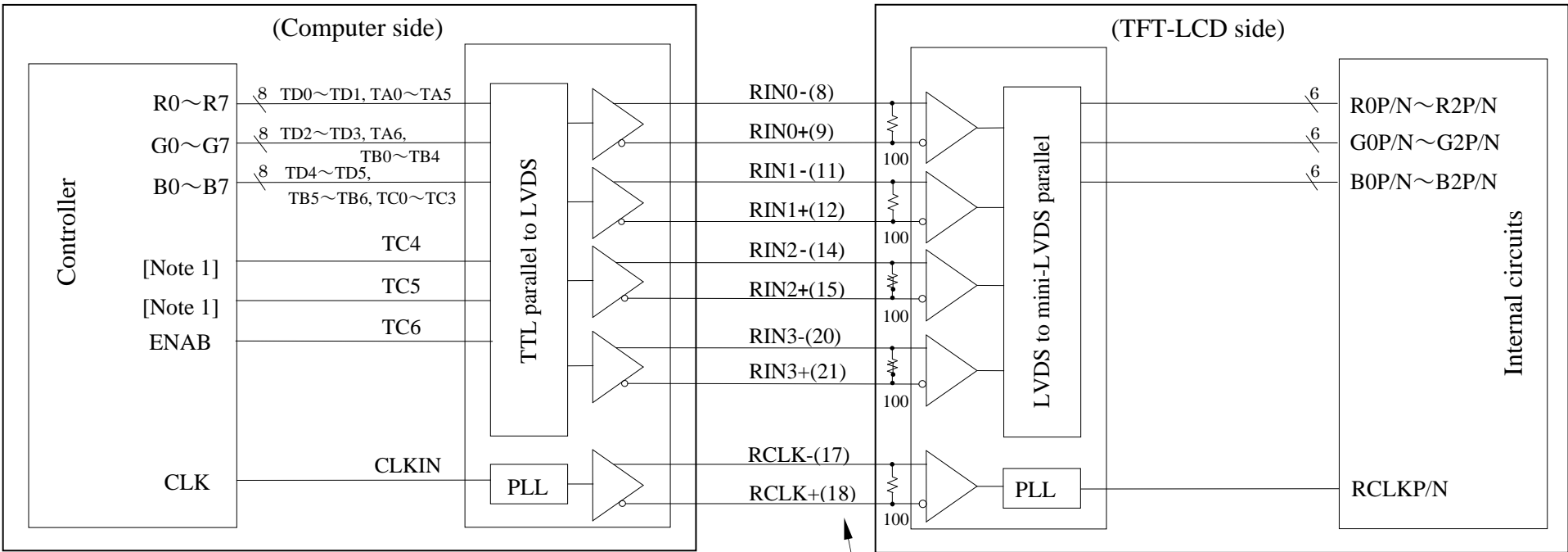

[Note 4-2-1] Do not use at high-impedance TC4, TC5.

Symbol of CN1 (Pin No.)



## 5. Absolute Maximum Ratings

Parameter	Symbol	Condition	Ratings		Unit	Remark
			Min.	Max.		
Input voltage	VI	Ta=25	-0.3	VDD	V	[Note 5-1]
+3.3V supply voltage	VDD	Ta=25	-0.3	+5.0	V	
Storage temperature (ambient)	Tstg	—	-20	+70		[Note 5-2]
Operating temperature (ambient)	Topa	—	-10	+60		
LED input electric current	I <sub>LED</sub>	Ta=25	—	35	mA	[Note5-3]
LED electricity consumption	P <sub>LED</sub>	Ta=25	—	119	mW	

[Note 5-1] LVDS signals

[Note 5-2] Humidity : 90%RH Max. at Ta +40 .

Maximum wet-bulb temperature at +39 or less at Ta>+40 .

No condensation.

[Note 5-3] Power consumption of one LED (Ta = 25°C). (use 42 pieces LED)

Ambient temperature and the maximum input are fulfilling the following operating conditions.

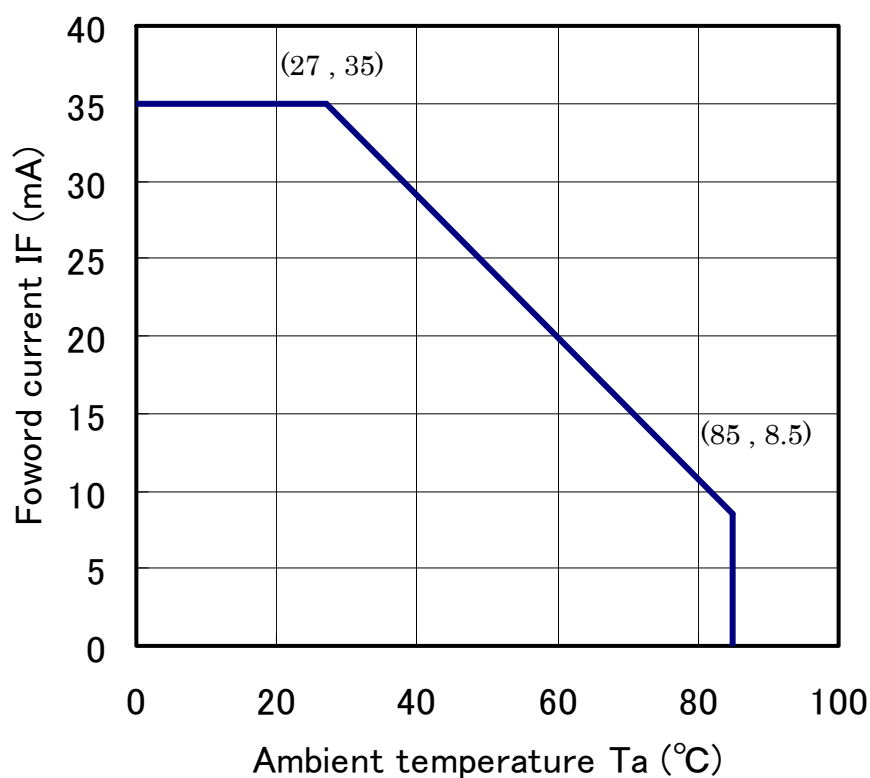

## 6. Electrical Characteristics

## 6 - 1. TFT-LCD panel driving

Ta = +25

Parameter	Symbol	Min.	Typ.	Max.	Unit	Remark
Supply voltage	VDD	+3.0	+3.3	+3.6	V	[Note 6-1-2]
Current dissipation	IDD	—	235	375	mA	[Note 6-1-3]
Permissible input ripple voltage	V <sub>RP</sub>	—	—	100	mV <sub>P-P</sub>	VDD = +3.3V
Input voltage range	V <sub>I</sub>	0	—	2.4	V	LVDS signals
Differential input threshold voltage	High	V <sub>TH</sub>	—	+100	mV	V <sub>CM</sub> = +1.2V [Note 6-1-1]
	Low	V <sub>TL</sub>	-100	—	mV	
Input current (High)	I <sub>OH</sub>	—	—	± 10	μ A	V <sub>I</sub> = +2.4V VDD = +3.6V
Input current (Low)	I <sub>OL</sub>	—	—	± 10	μ A	V <sub>I</sub> = 0V VDD = 3.6V
Termination resistor	R <sub>T</sub>	—	100	—		Differential input

[Note 6-1-1] V<sub>CM</sub> : Common mode voltage of LVDS driver.

[Note 6-1-2] ON-OFF conditions for supply voltage

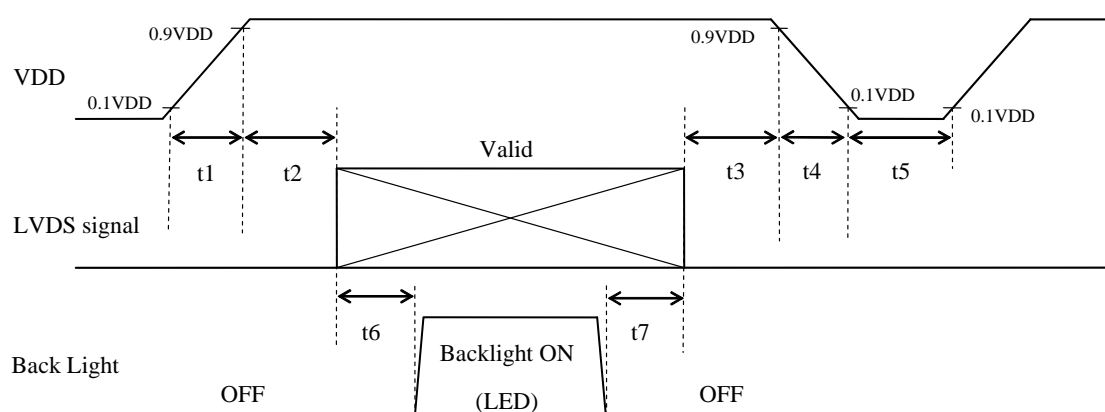

Symbol	Min	Max	Unit	Note
t1	0	10	ms	
t2	0	1	s	
t3	0	1	s	
t4	0	400	ms	
t5	200	—	ms	
t6	180	—	ms	*1
t7	5	—	ms	*1

\*1 : As for the power sequence for backlight, it is recommended to apply above mentioned input timing.

If the backlight is lit on and off at a timing other than shown above, displaying image may get disturbed. This is due to variation of output signal from timing generator when LVDS signal is changed from on to off or vice versa, but has no harm to the module itself.

[Note] Do not keep the interface signal high-impedance or unusual signal when power is on.

VDD-dip conditions

- 1) 2.5 V  $VDD < 3.0$  V  
 $t_d$  10 ms

Under above condition, the display image should return to an appropriate figure after VDD voltage recovers.

- 2)  $VDD < 2.5$  V  
 VDD-dip conditions should also follow the ON-OFF conditions for supply voltage

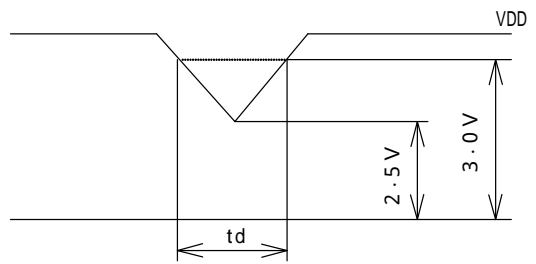

[Note 6-1-3] Typical current condition: 16-gray-bar pattern.

$VDD = +3.3$  V

Maximum current condition:  $VDD = +3.0$  V

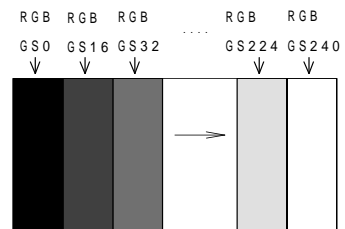

6 - 2. LVDS input specification

6 - 2 - 1. AC characteristics

VDD=+3.0V~+3.6V, Ta=-10°C~+60

Parameter	Symbol	Min	Typ.	Max.	Unit
Input Data Position 0 (t <sub>RCIP</sub> =15.38ns)	t <sub>RIP1</sub>	-0.25	0.0	+0.25	ns
Input Data Position 1 (t <sub>RCIP</sub> =15.38ns)	t <sub>RIP0</sub>	t <sub>RCIP</sub> /7-0.25	t <sub>RCIP</sub> /7	t <sub>RCIP</sub> /7+0.25	ns
Input Data Position 2 (t <sub>RCIP</sub> =15.38ns)	t <sub>RIP6</sub>	2 t <sub>RCIP</sub> /7-0.25	2 t <sub>RCIP</sub> /7	2 t <sub>RCIP</sub> /7+0.25	ns
Input Data Position 3 (t <sub>RCIP</sub> =15.38ns)	t <sub>RIP5</sub>	3 t <sub>RCIP</sub> /7-0.25	3 t <sub>RCIP</sub> /7	3 t <sub>RCIP</sub> /7+0.25	ns
Input Data Position 4 (t <sub>RCIP</sub> =15.38ns)	t <sub>RIP4</sub>	4 t <sub>RCIP</sub> /7-0.25	4 t <sub>RCIP</sub> /7	4 t <sub>RCIP</sub> /7+0.25	ns
Input Data Position 5 (t <sub>RCIP</sub> =15.38ns)	t <sub>RIP3</sub>	5 t <sub>RCIP</sub> /7-0.25	5 t <sub>RCIP</sub> /7	5 t <sub>RCIP</sub> /7+0.25	ns
Input Data Position 6 (t <sub>RCIP</sub> =15.38ns)	t <sub>RIP2</sub>	6 t <sub>RCIP</sub> /7-0.25	6 t <sub>RCIP</sub> /7	6 t <sub>RCIP</sub> /7+0.25	ns
Phase Lock Loop Set	t <sub>RPLL</sub>	—	—	1	ms
Input Clock Period	t <sub>RCIP</sub>	12.5	15.38	16.67	ns

LVDS input timing

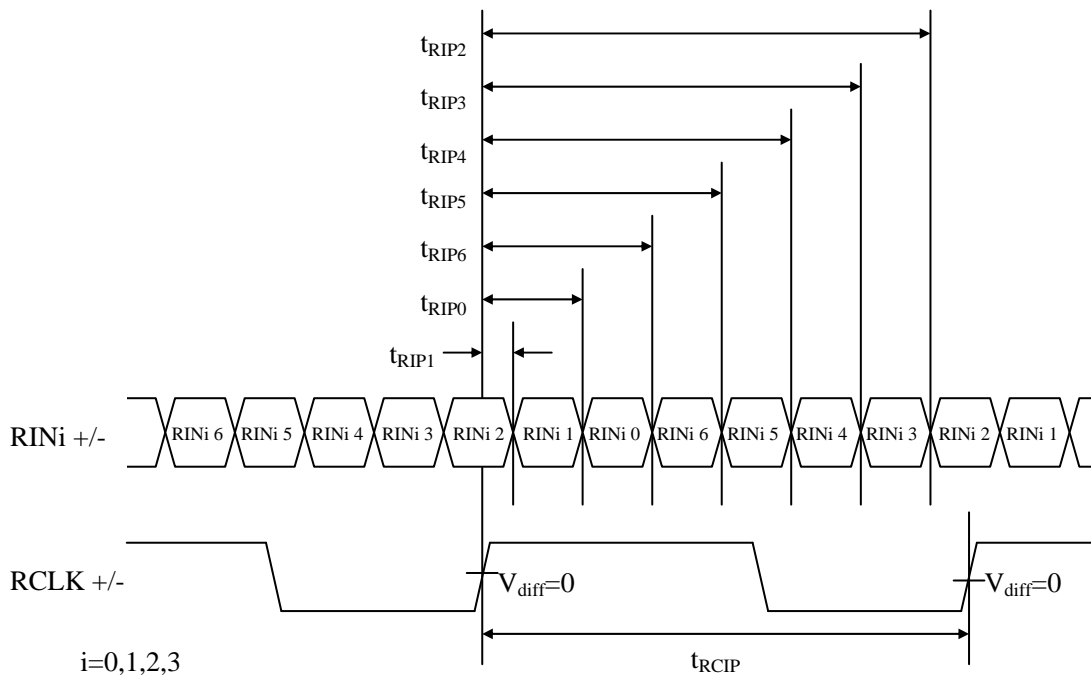

Note  
V<sub>diff</sub>=(RIN<sub>i</sub>+)-(RIN<sub>i</sub>-), (RCLK+)-(RCLK-)

LVDS phase lock loop set

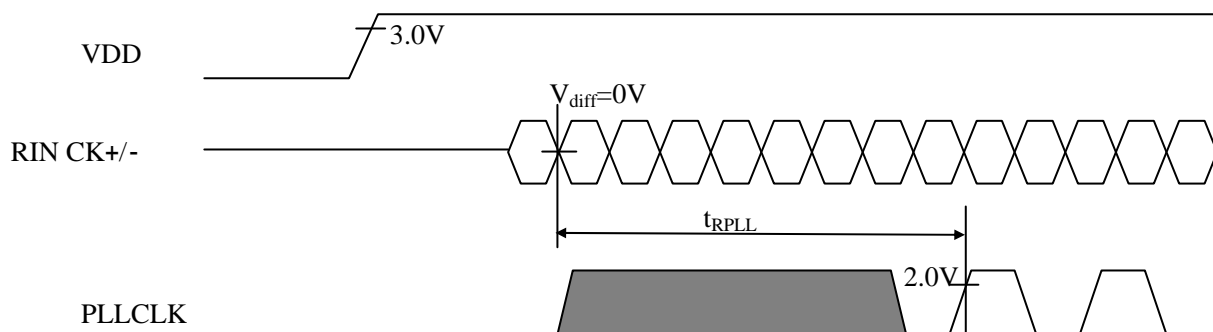

6 - 2 - 2. LVDS data

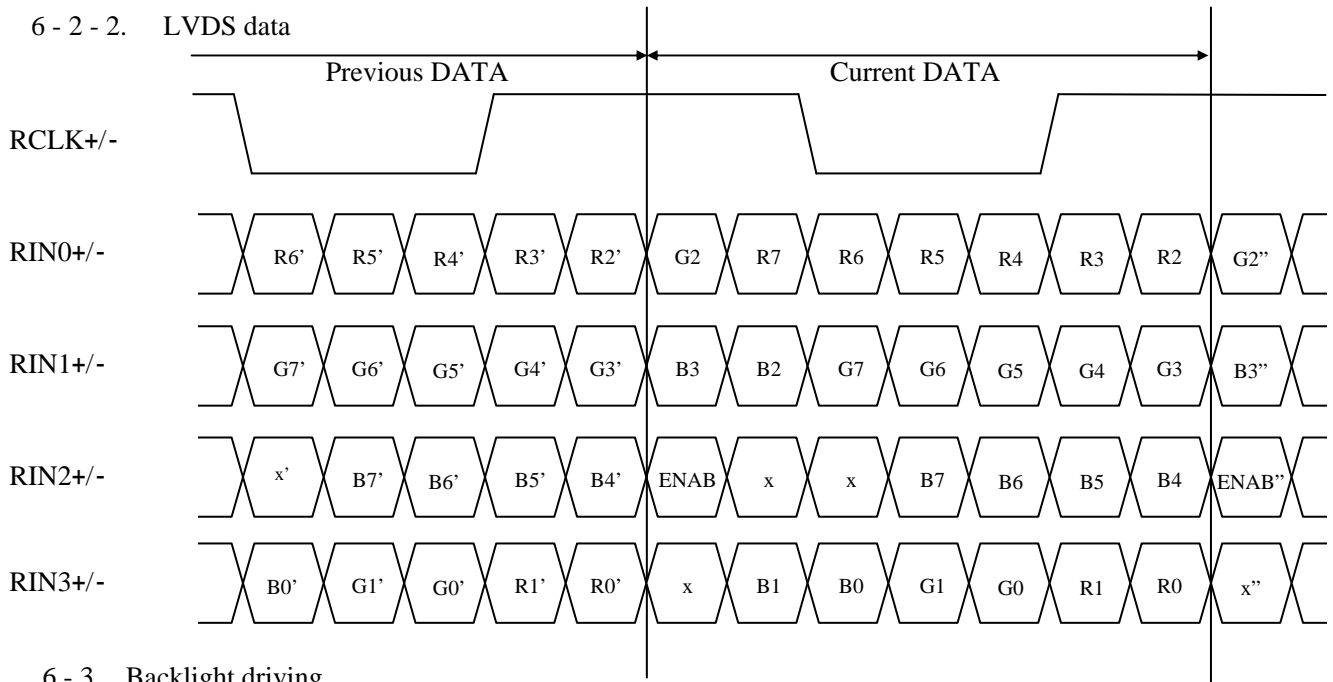

6 - 3. Backlight driving

The backlight system has 42 pieces LED (6 strings of 7 LEDs each)

- Normal operation (400cd / m<sup>2</sup>)

Parameter	Symbol	Min.	Typ.	Max.	Unit	Remark
Rated Voltage	V <sub>BL</sub>	-	21.0	24.5	V	For 1 strings
Rated Current	I <sub>L</sub>	-	15.5	-	mA	Ta=25°C
Power consumption	W <sub>L</sub>	-	1.95	-	W	For 6 strings
LED life time	L <sub>L</sub>	-	20,000	-	Hour	[Note 6-3-1]



[LED circuit]

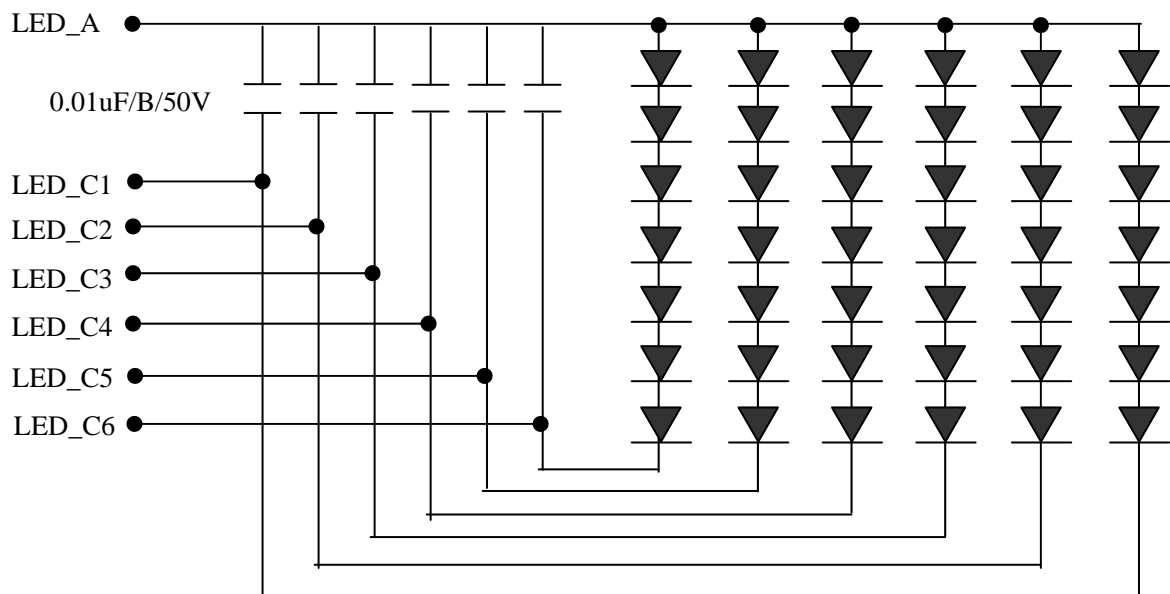

[Note 6-3-1] LED life time is defined as the time when Brightness becomes 50 % of the original value under the condition of Ta = 25 , I<sub>L</sub> = 15.5 mA and continuous lighting.

## 7. Timing Characteristics of Input Signals

## 7 - 1. Timing characteristics

VDD=+3.0V~+3.6V, Ta=-10°C~+60

	Parameter	Symbol	Min.	Typ.	Max.	Unit	Remark
Clock	Frequency	1/Tc	60	65	80	MHz	[Note 7-1-1]
Data enable Signal	Horizontal period	TH	—	1330	—	clock	
			19.5	20.5	21.5	μs	
	Horizontal period (High)	THd	—	1280	—	clock	
	Vertical period	TV	—	812	—	Line	
			—	16.67	—	ms	
Vertical period (High)	TVd	—	800	—	line		

[Note 7-1-1] In case of using the long vertical period, the deterioration of display quality, flicker, etc. may occur.

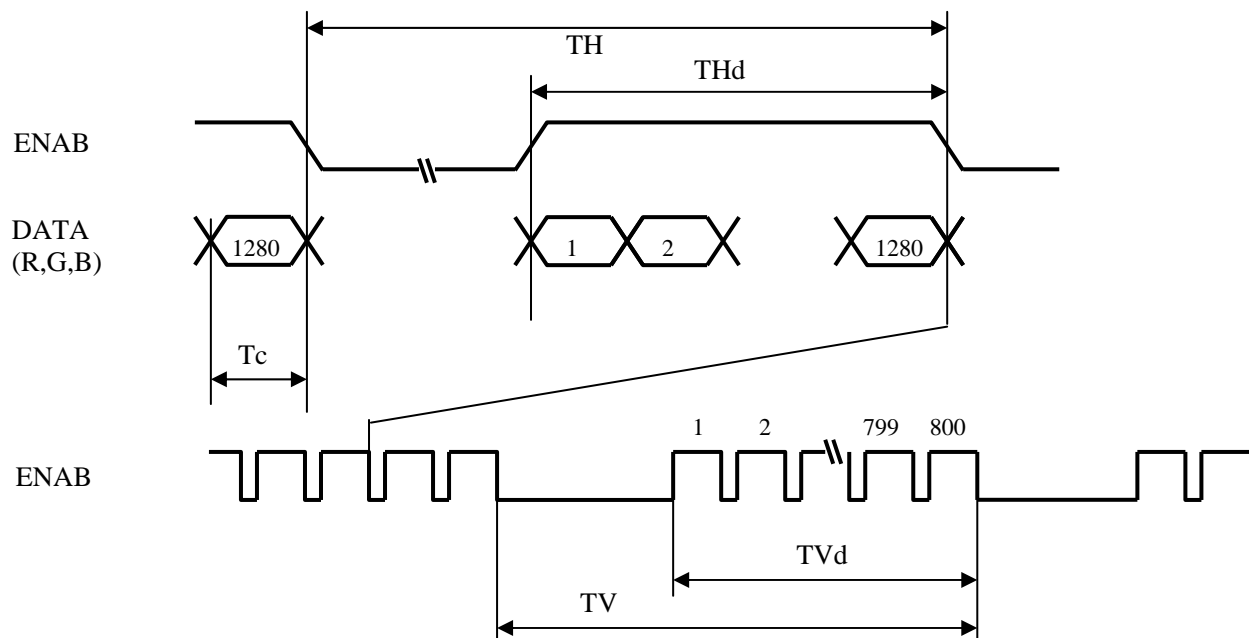

## 7 - 2. Input data signals and display position on the screen

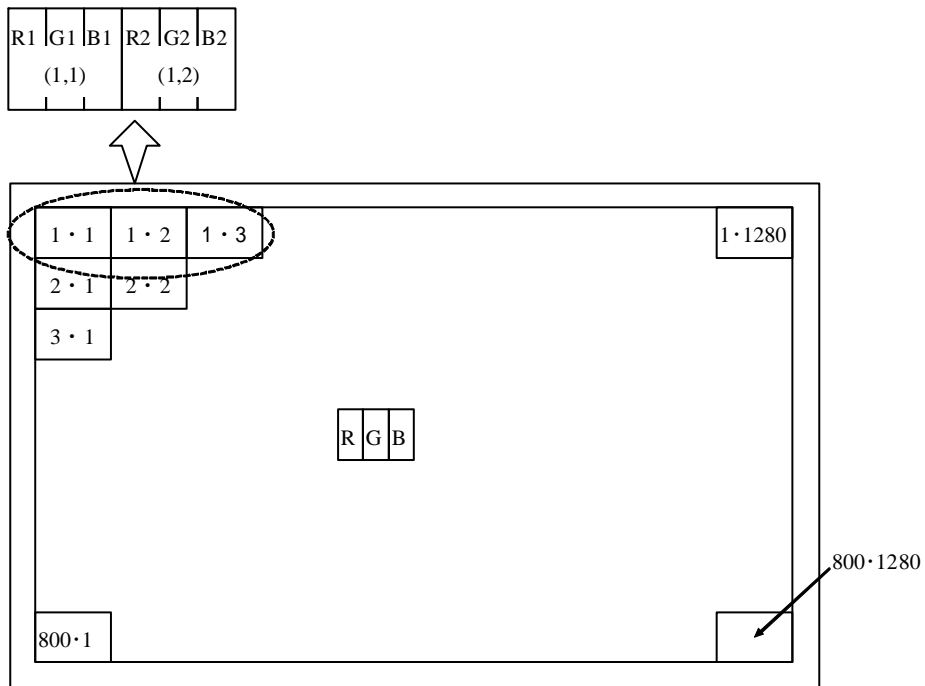

Display position of input data(V · H)

8. Input Signals, Basic Display Colors and Gray Scale of Each Color

Colors & Gray Scale	Date signal																															
	Gray Scale	R0	R1	R2	R3	R4	R5	R6	R7	G0	G1	G2	G3	G4	G5	G6	G7	B0	B1	B2	B3	B4	B5	B6	B7							
		LSB								MSB								LSB								MSB						
Basic Color	Black	—	0	0	0	0	0	0	0	0	0	0	0	0	0	0	0	0	0	0	0	0	0	0	0							
	Blue	—	0	0	0	0	0	0	0	0	0	0	0	0	0	0	0	0	1	1	1	1	1	1	1							
	Green	—	0	0	0	0	0	0	0	0	1	1	1	1	1	1	1	1	0	0	0	0	0	0	0							
	Cyan	—	0	0	0	0	0	0	0	0	1	1	1	1	1	1	1	1	1	1	1	1	1	1	1							
	Red	—	1	1	1	1	1	1	1	1	0	0	0	0	0	0	0	0	0	0	0	0	0	0	0							
	Magenta	—	1	1	1	1	1	1	1	1	0	0	0	0	0	0	0	0	1	1	1	1	1	1	1							
	Yellow	—	1	1	1	1	1	1	1	1	1	1	1	1	1	1	1	1	0	0	0	0	0	0	0							
	White	—	1	1	1	1	1	1	1	1	1	1	1	1	1	1	1	1	1	1	1	1	1	1	1							
Gray Scale of Red	Black	GS0	0	0	0	0	0	0	0	0	0	0	0	0	0	0	0	0	0	0	0	0	0	0								
	↑	GS1	1	0	0	0	0	0	0	0	0	0	0	0	0	0	0	0	0	0	0	0	0	0								
	Darker	GS2	0	1	0	0	0	0	0	0	0	0	0	0	0	0	0	0	0	0	0	0	0	0								
	↑	↓	↓								↓								↓													
	↓	↓	↓								↓								↓													
	Brighter	GS253	1	0	1	1	1	1	1	1	0	0	0	0	0	0	0	0	0	0	0	0	0	0	0							
	↓	GS254	0	1	1	1	1	1	1	1	0	0	0	0	0	0	0	0	0	0	0	0	0	0	0							
	Red	GS255	1	1	1	1	1	1	1	1	0	0	0	0	0	0	0	0	0	0	0	0	0	0	0							
Gray Scale of Green	Black	GS0	0	0	0	0	0	0	0	0	0	0	0	0	0	0	0	0	0	0	0	0	0	0								
	↑	GS1	0	0	0	0	0	0	0	0	1	0	0	0	0	0	0	0	0	0	0	0	0	0								
	Darker	GS2	0	0	0	0	0	0	0	0	0	1	0	0	0	0	0	0	0	0	0	0	0	0								
	↑	↓	↓								↓								↓													
	↓	↓	↓								↓								↓													
	Brighter	GS253	0	0	0	0	0	0	0	0	1	0	1	1	1	1	1	1	0	0	0	0	0	0	0							
	↓	GS254	0	0	0	0	0	0	0	0	0	1	1	1	1	1	1	1	0	0	0	0	0	0	0							
	Green	GS255	0	0	0	0	0	0	0	0	1	1	1	1	1	1	1	1	0	0	0	0	0	0	0							
Gray Scale of Blue	Black	GS0	0	0	0	0	0	0	0	0	0	0	0	0	0	0	0	0	0	0	0	0	0	0								
	↑	GS1	0	0	0	0	0	0	0	0	0	0	0	0	0	0	0	0	1	0	0	0	0	0								
	Darker	GS2	0	0	0	0	0	0	0	0	0	0	0	0	0	0	0	0	0	1	0	0	0	0								
	↑	↓	↓								↓								↓													
	↓	↓	↓								↓								↓													
	Brighter	GS253	0	0	0	0	0	0	0	0	0	0	0	0	0	0	0	0	1	0	1	1	1	1	1							
	↓	GS254	0	0	0	0	0	0	0	0	0	0	0	0	0	0	0	0	0	1	1	1	1	1	1							
	Blue	GS255	0	0	0	0	0	0	0	0	0	0	0	0	0	0	0	0	1	1	1	1	1	1	1							

0 : Low level voltage, 1 : High level voltage

Each basic color can be displayed in 256 gray scales from 8 bit data signals.

According to the combination of 24 bit data signals, the 16.7M color display can be achieved on the screen.



## 9. Optical Characteristics

Ta=+25 , VDD=+3.3V

Parameter		Symbol	Condition	Min.	Typ.	Max.	Unit	Remark
Viewing angle range	Horizontal	21, 22	CR>10	70	80	—	deg.	[Note 9-1, 9-3, 9-4, 9-6]
	Vertical	11		70	80	—	deg.	
		12		70	80	—	deg.	
Contrast ratio		CR	=0 °	600	800	—		[Note 9-2, 9-4, 9-6]
Response time		r+ d	=0 °	—	25	—	ms	[Note 9-2, 9-5, 9-6]
Chromaticity of white		x		0.268	0.318	0.368		[Note 9-2, 9-6]
		y		0.294	0.344	0.394		
Chromaticity of red		x		0.531	0.581	0.631		
		y		0.291	0.341	0.391		
Chromaticity of green		x		0.285	0.335	0.385		
		y		0.535	0.585	0.635		
Chromaticity of blue		x		0.095	0.145	0.195		
		y		0.080	0.130	0.180		
Luminance of white [Note 2,6]		Y <sub>LI</sub>		300	400	—	cd/m <sup>2</sup>	
White Uniformity		w		—	1.25	1.43		[Note 9-2, 9-7]

The measurement shall be taken 30 minutes after lighting the module at the following rating:

Condition: I<sub>L</sub> = 15.5mA.

The optical characteristics shall be measured in a dark room or equivalent.

[Note 9-1] Measuring Viewing Angle Range

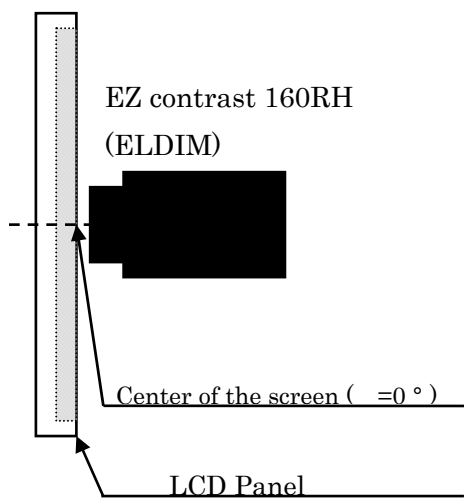

[Note 9-2] Other Measurements

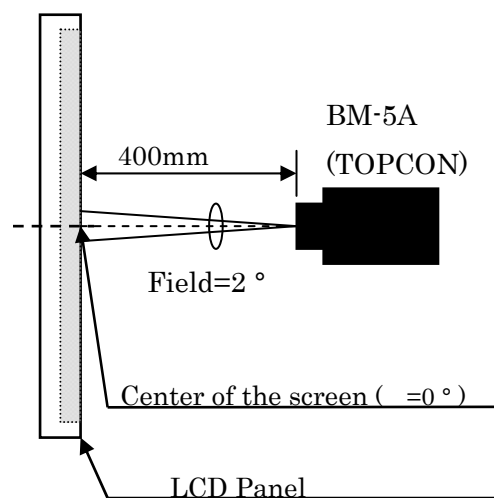

[Note 9-3] Definitions of viewing angle range:

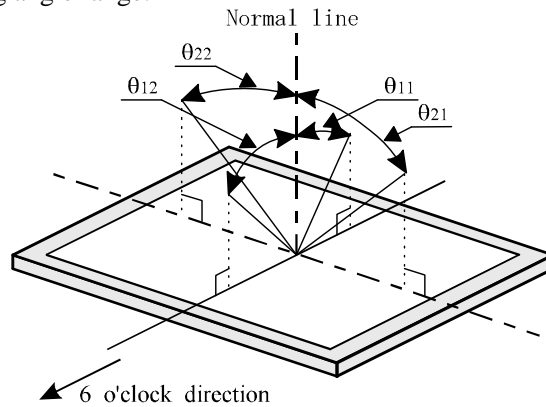

[Note 9-4] Definition of contrast ratio:

The contrast ratio is defined as the following.

$$\text{Contrast Ratio (CR)} = \frac{\text{Luminance (brightness) with all pixels white}}{\text{Luminance (brightness) with all pixels black}}$$

[Note 9-5] Definition of response time:

The response time is defined as the following figure and shall be measured by switching the input signal for "black" and "white" .

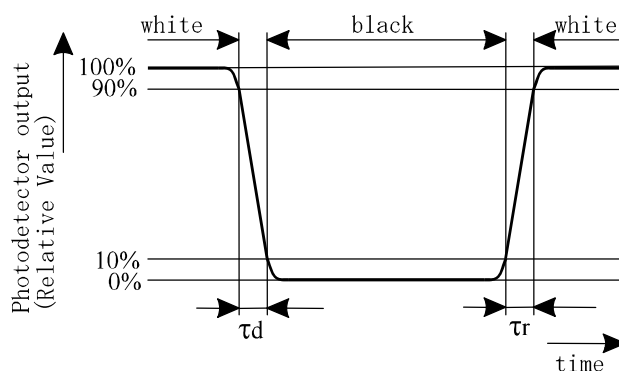

[Note 9-6] This shall be measured at center of the screen.

[Note 9-7] Definition of white uniformity:

White uniformity is defined as the following with nine measurements (A~E).

$$w = \frac{\text{Maximum Luminance of nine points (brightness)}}{\text{Minimum Luminance of nine points (brightness)}}$$

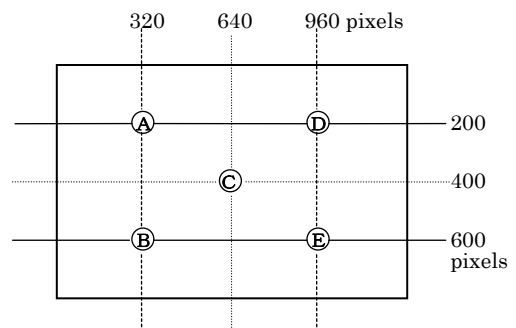

## 10. Display Quality

The display quality of the color TFT-LCD module shall be in compliance with the Incoming Inspection Standard.

## 11. Handling Precautions

- a) Be sure to turn off the power supply when inserting or disconnecting the cable.  
Please insert for too much stress not to join a connector in the case of insertion of a connector.
- b) Be sure to design the cabinet so that the module can be installed without any extra stress such as warp or twist.
- c) Since the front polarizer is easily damaged, pay attention not to scratch it.
- d) Wipe off water drop immediately. Long contact with water may cause discoloration or spots.
- e) When the panel surface is soiled, wipe it with absorbent cotton or other soft cloth.
- f) Since the panel is made of glass, it may break or crack if dropped or bumped on hard surface. Handle with care.
- g) Since CMOS LSI is used in this module, take care of static electricity and injure the human earth when handling. Observe all other precautionary requirements in handling components.
- h) This module has its circuitry PCBs on the rear side and should be handled carefully in order not to be stressed.
- i) Protect sheet(Laminate film) is attached to the module surface to prevent it from being scratched. Peel the sheet off slowly just before the use with strict attention to electrostatic charges. Ionized air shall be blown over during the action. Blow off the 'dust' on the polarizer by using an ionized nitrogen gun, etc. Working under the following environments is desirable.
  - All workers wear conductive shoes, conductive clothes, conductive fingerstalls and grounding belts without fail.
  - Use Ionized blower for electrostatic removal, and peel of the protect sheet with a constant speed. (Peeling of it at over 2 seconds)
- j) The polarizer surface on the panel is treated with Glare and Low reflection. In case of attaching protective board over the LCD, be careful about the optical interface fringe etc. which degrades display quality.
- k) Do not expose the LCD module to a direct sunlight, for a long period of time to protect the module from the ultra violet ray.
- l) When handling LCD modules and assembling them into cabinets, please be noted that long-term storage in the environment of oxidization or deoxidization gas and the use of such materials as reagent, solvent, adhesive, resin, etc. which generate these gasses, may cause corrosion and discoloration of the LCD modules.
- m) Liquid crystal contained in the panel may leak if the LCD is broken. Rinse it as soon as possible if it gets inside your eye or mouth by mistake.
- n) Disassembling the module can cause permanent damage and should be strictly avoided.  
Please don't remove the fixed tape, insulating tape etc that was pasted on the original module.  
(Except for protection film of the panel.)
- o) Be careful when using it for long time with fixed pattern display as it may cause afterimage.  
(Please use a screen saver etc., in order to avoid an afterimage.)
- p) Adjusting volume have been set optimally before shipment, so do not change any adjusted value. If adjusted value is changed, the specification may not be satisfied.
- q) If a minute particle enters in the module and adheres to an optical material, it may cause display non-uniformity issue, etc. Therefore, fine-pitch filters have to be installed to cooling and inhalation hole if you intend to install a fan.
- r) Epoxy resin (amine series curing agent), silicone adhesive material (dealcoholization series and oxime series), tray forming agent (azo compound) etc, in the cabinet or the packing materials may induce abnormal display with polarizer film deterioration regardless of contact or noncontact to polarizer film.  
Be sure to confirm the component of them.
- s) Do not use polychloroprene. If you use it, there is some possibility of generating Cl<sub>2</sub> gas that influences the reliability of the connection between LCD panel and driver IC.

t) Do not put a laminate film on LCD module, after peeling of the original one. If you put on it, it may cause discoloration or spots because of the occurrence of air gaps between the polarizer and the film.

u) Ground module bezel to stabilize against EMI and external noise.

△v) To avoid deforming ribs of the front bezel and unfastening joints of front bezel-backlight, we recommend supporting metal case area from rear side ( example is below ).

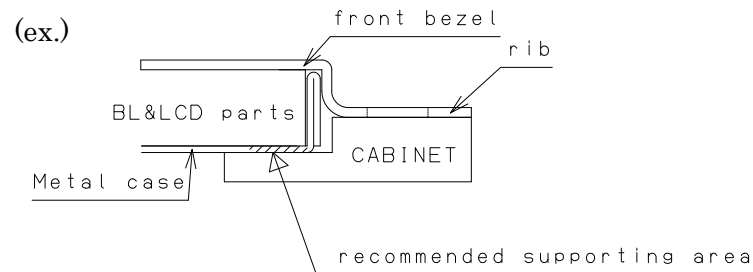

## 12. Packaging Condition

Piling number of cartons	MAX.8
Package quantity in one carton	40pcs
Carton size	380(W)×575(D)×225(H)
Total mass of one carton filled with full modules	10.8kg
Packing form	Fig.1

13. Label

1) Module Bar code label:

Model.No.      Barcode( Model No.)      Serial No.

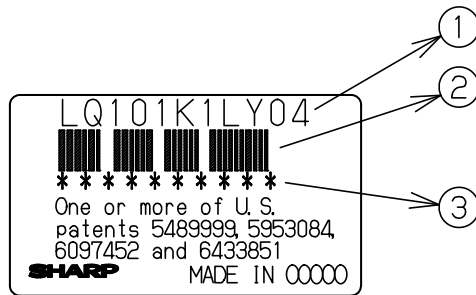

Serial No.

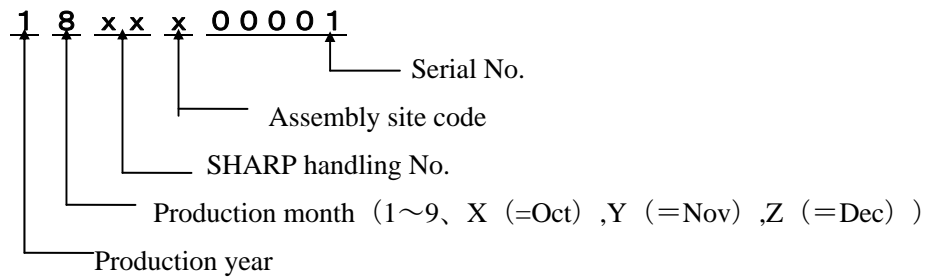

2) Packing bar code label

Notation/ Bar code:      Model No.      Date      Quantity

(40pcs / Carton )

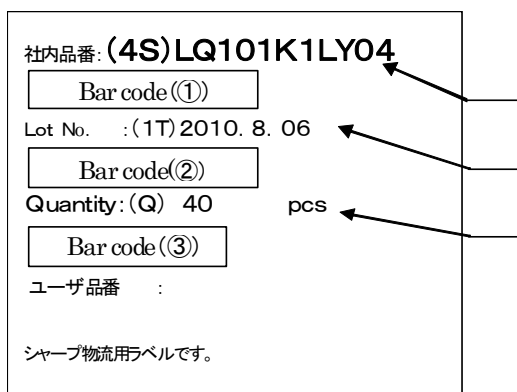

14. RoHS Directive

This LCD module is compliant with RoHS Directive.

## 15. Reliability Test Items

No.	Test item	Conditions
1	High temperature storage test	Ta = 70 240h
2	Low temperature storage test	Ta = -20 240h
3	High temperature & high humidity operation test	Ta = 40 ; 90%RH 240h (No condensation)
4	High temperature operation test	Ta = 60 240h
5	Low temperature operation test	Ta = -10 240h
6	Thermal Shock Test (non- operating)	+70 (1hours) -20 (1hours) 2hours per cycle Temperature change time:10 /minute Tested for 5 cycles
7	Vibration test (non- operating)	Frequency:10~57Hz/Vibration width (one side):0.076mm :57~500Hz/acceleration:9.8m/s <sup>2</sup> Sweep time: 11minutes Test period: 1 hour for each direction of X,Y,Z
8	Shock test (non- operating)	Max. gravity : 490 m/s <sup>2</sup> Pulse width : 11 ms, half sine wave Direction : ± X, ± Y, ± Z once for each direction.
9	ESD	± 200V, 200pF(0Ω) 1time/each terminal

[Result Evaluation Criteria] Under the display quality test conditions with normal operation state.

Do not change these conditions as such changes may affect practical display function.

[Normal operation state] Temperature : +15~+35 , Humidity : 45~75%, Atmospheric pressure : 86~106kPa

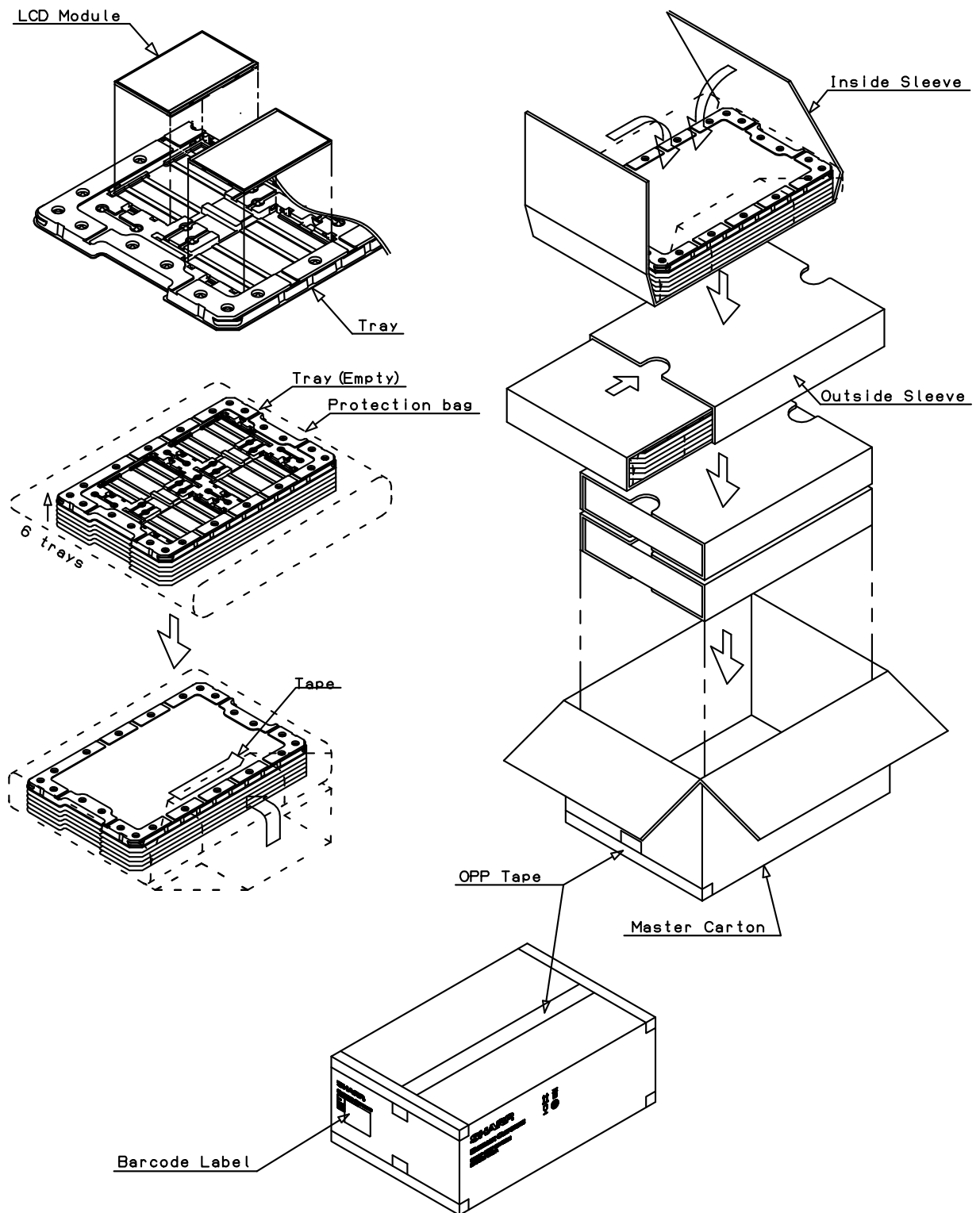
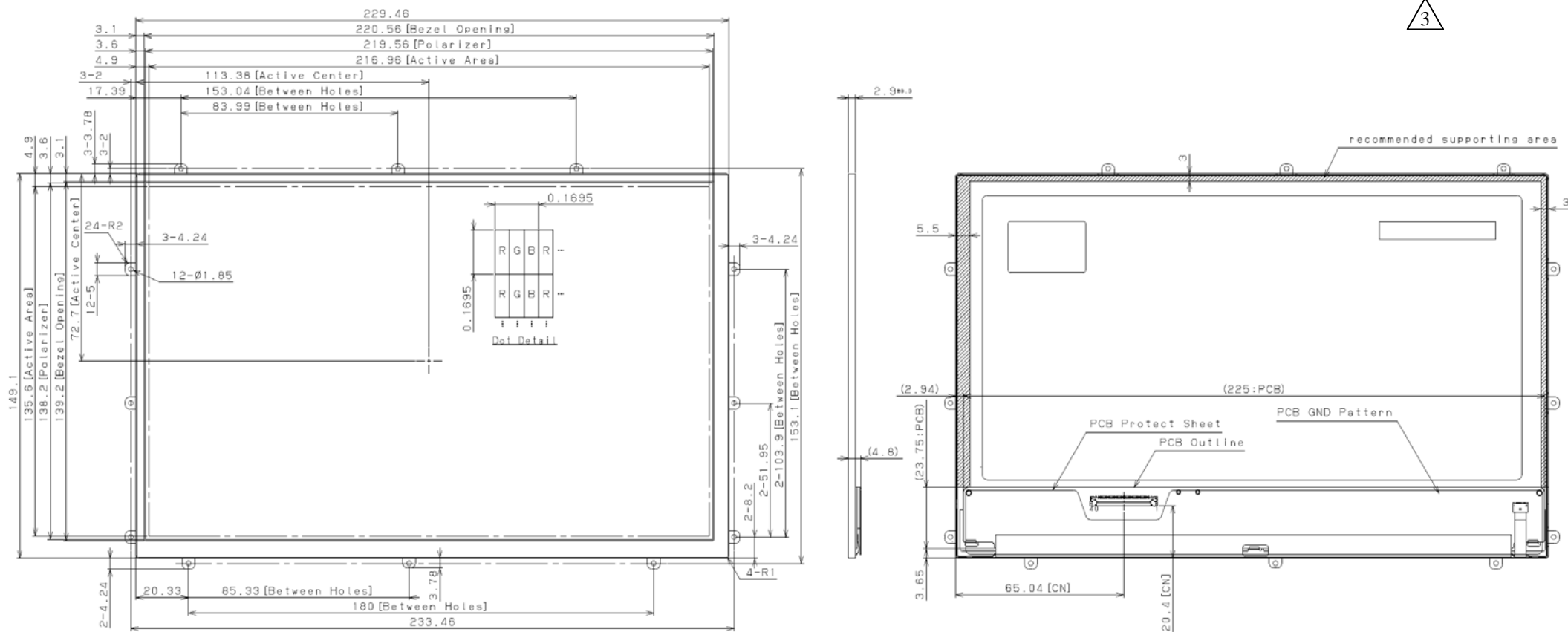

Fig. 1 Packaging Condition



NOTES  
 -UNSPECIFIED TOLERANCE TO BE ±0.5

D/N:2D-118-021-02

Fig. 2 Outline Dimensions